

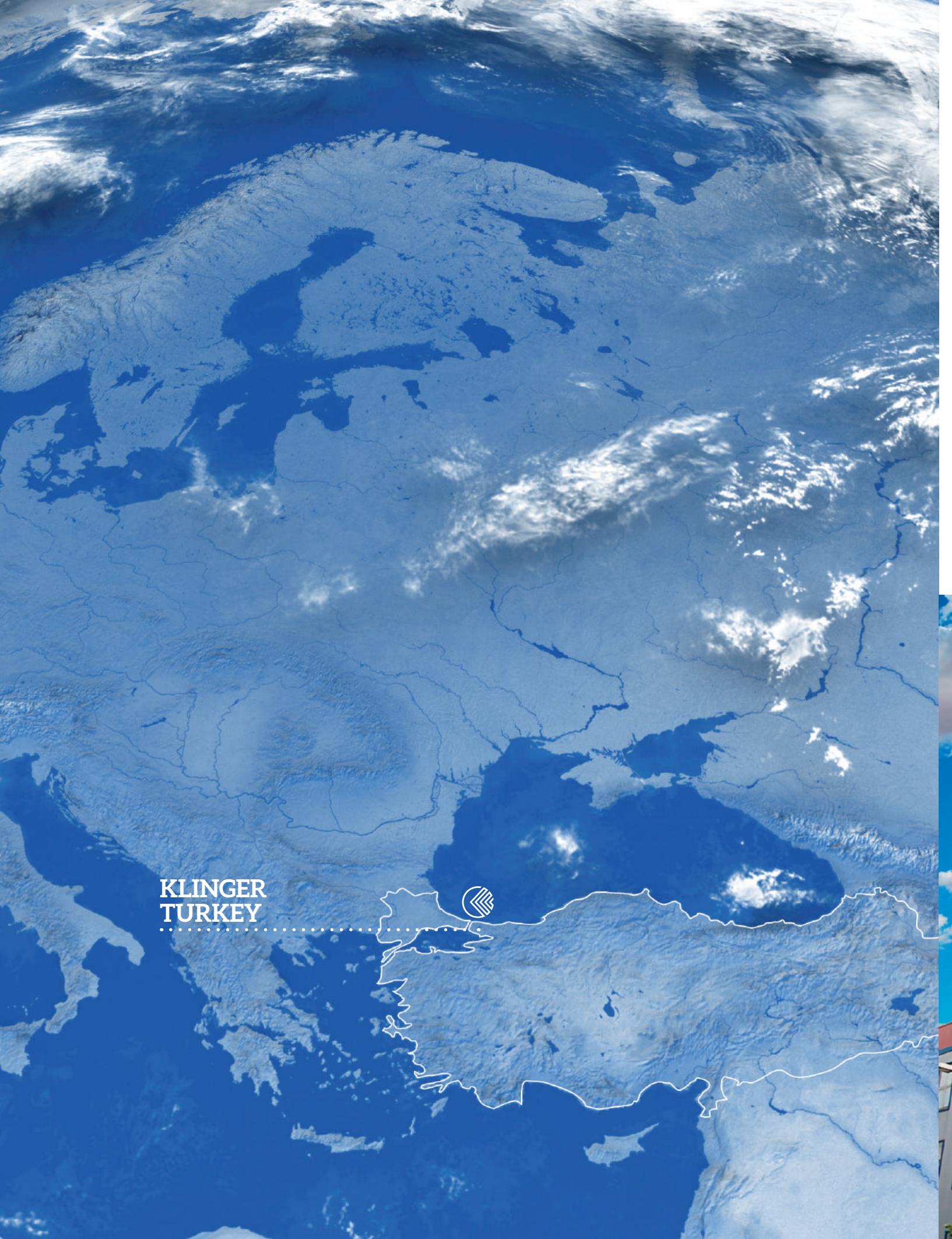

EXPANSION JOINTS & FLEXIBLE METAL HOSES





**KLINGER
TURKEY**



KLINGER TURKEY

With over 45 years of experience in the design and manufacturing of expansion joints and flexible metal hoses, our engineering group is proud of offering fast and economical solutions with high quality, utilizing modern technologies.

KLINGER Turkey has been offering a wide range of expansion joints and flexible metal hoses in addition to standard types since its first days. KLINGER Turkey can design and manufacture high pressure, large diameter and various types of flexible solutions.

All of our products are designed and manufactured by our own engineers and manufacturing personnel. This ensures the quality and reliability of our products.

With over 9.000 square meter of manufacturing area and supplying to well-known customers worldwide since 1976, KLINGER Turkey is the address our customers choose when they want a fast, high quality and reliable product.

KLINGER was founded in 1886 as a family business and is known as a pioneer in sealing technology. Serving a global client base, it delivers trusted products worldwide for petro-chemical, chemical, process industries, infrastructure, and transportation applications. Today, the group comprises of 40 companies and more than 60 manufacturing, distribution and service hubs worldwide.

MANUFACTURING

Bellows and hoses can be manufactured in various materials such as 304, 316, 321, 309S, 310S, 904L, Duplex 2205, Duplex 2507, Alloy 625 Alloy 825, Alloy 800H and other nickel alloys.

QUALITY

KLINGER Turkey is fully committed to a quality management process with quality as a fundamental business principle. Core of the process is achieving customer satisfaction by meeting our internal and customer requirements on time.

DESIGN

Designing for a wide range of parameters allows product solutions to be developed both quickly and effectively.



Mission

Being customer oriented
Offering fast, reliable and high quality products
Exceeding customers' expectations

Values

Our values are part of our DNA and serve as a compass for our actions.

Vision

We design and manufacture expansion joints and flexible metal hoses to worldwide industry standards.

Being a part of KLINGER group, social and environmental responsibilities are taken very seriously by KLINGER Turkey and our employees. We are confident that with our strong team we will continue to grow to be one of the largest expansion joint and flexible metal hose manufacturers in the world.

CERTIFICATES

Expansion Joints

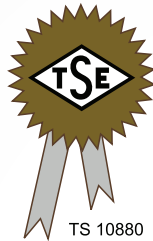

Flexible Metal Hoses

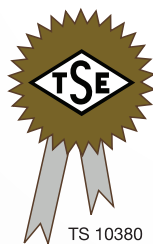

As a part of the KLINGER Group, KLINGER Turkey has been developing, manufacturing high-quality expansion joints and flexible metal hoses in Istanbul/Turkey for more than 45 years. Via our global distribution and service network, KLINGER Turkey offers both standardized and special products, services as well as solutions for customers around the globe.

Products from KLINGER Turkey are characterized by their high level of reliability as well as by above average life cycle at a very low total cost of ownership (TCO). As a trusted solutions partner, KLINGER Turkey creates customer benefits with added value. In this regard, the focus is on the following core competences:

ENCOMPASSING SERVICE

- » Application expertise
- » Product trainings
- » Fast quotation and order processing
- » Customer-specific solutions
- » On-site technical support

PRODUCT SOLUTIONS

- » High level product knowledge
- » Product tests in the in-house technical center
- » A wide range of certificates and approvals

OPERATIONAL EXCELLENCE

- » Flexible production
- » Short delivery time
- » Fast logistic support

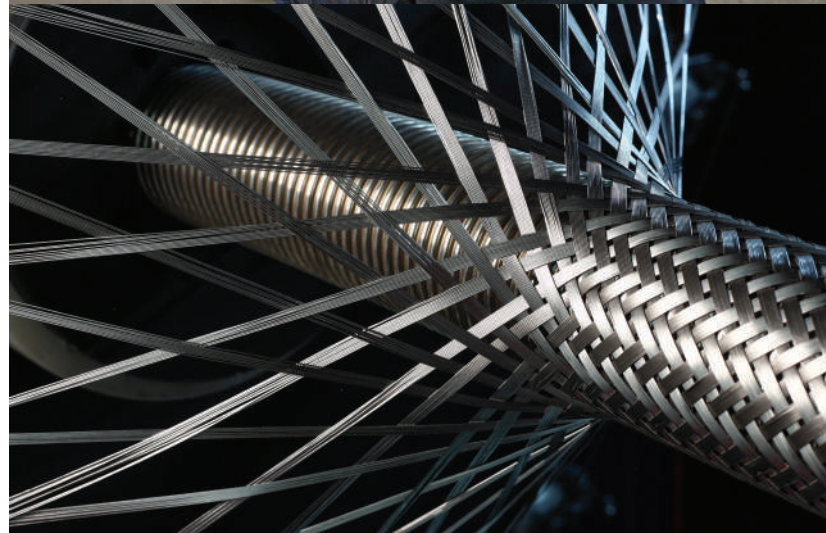

WELD END

Expansion Joints

Weld end type expansion joints comes with various grades of carbon and stainless steel or nickel alloy pipe connections. These pipe connection dimensions can be in accordance with various industry standards or be manufactured specially for your needs. KLINGER Turkey has a wide range of manufacturing capabilities to supply custom designed solutions.

This type expansion joints are commonly used at many industries and applications safely. They can be designed in single or universal expansion joint form depending on design conditions.

They are mainly used where pressures are high, welding is not a problem and leakage is of concern. They are more economical than flanged types since flanges are more costly than pipes. Also, no gaskets are needed for connections and they are maintenance free.

Applications

- » District heating
- » Steam lines
- » Chemical and process industries
- » Steel and iron industries
- » Pulp and paper industry
- » Water (hot and cold) lines
- » Marine applications, exhaust systems
- » Geothermal applications

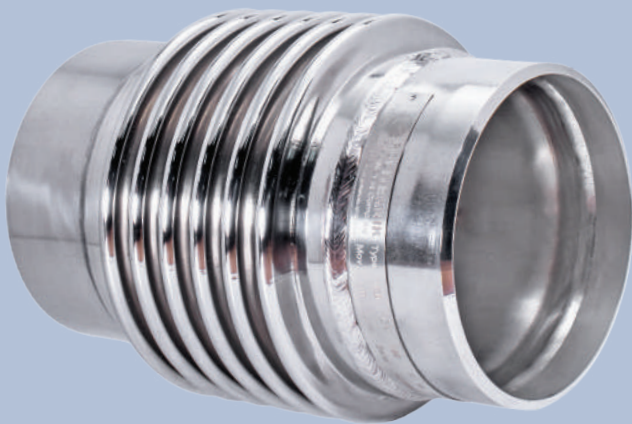

DESIGN VALUES

Bellows Material	304, 316, 321
Weld End Material	Carbon Steel, Stainless Steel
Design Pressure	2,5 barg
Design Temperature	550°C

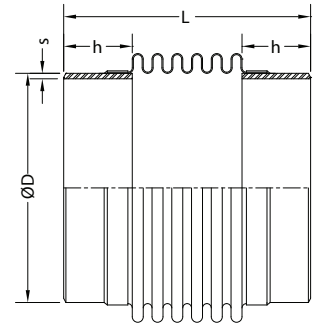

PN 2,5

DN	Type	Length (L) (mm)	Movements		Spring Rates		Effective Area (cm ²)	Weld-End		
			Axial (+/-) (mm)	Lateral (+/-) (mm)	Axial (N/mm)	Lateral (N/mm)		ØD (mm)	s (mm)	h (mm)
32	L	255	16	17	31	4	19	42,4	3	50
	S	185	8	5	57	26				
40	L	255	18	17	27	5	26	48,3	3	50
	S	185	10	5	50	29				
50	L	255	29	22	30	9	39	60,3	4	50
	S	205	20	10	44	27				
65	L	260	33	21	32	13	58	76,1	4	50
	S	205	22	9	48	45				
80	L	265	40	22	27	14	80	88,9	4	50
	S	205	24	9	46	58				
100	L	295	35	16	60	45	129	114,3	4	60
	S	225	23	6	82	166				
125	L	304	36	15	67	66	187	139,7	4	60
	S	237	26	7	85	202				
150	L	304	50	17	44	62	271	168,3	5	60
	S	225	30	6	65	274				
200	L	325	64	19	41	78	452	219,1	5	60
	S	225	40	6	58	389				
250	L	365	70	16	42	42	684	273	5	80
	S	265	40	5	68	683				
300	L	385	70	16	50	161	945	323,9	6	80
	S	265	40	4	78	1.076				
350	L	425	65	16	47	181	1.133	355,6	6	100
	S	295	35	3	102	1.993				
400	L	425	65	14	51	255	1.478	406,4	6	100
	S	300	30	2	65	1.507				
450	L	420	70	13	51	329	1.839	457,2	6	100
	S	310	35	2	80	2.001				
500	L	420	85	13	44	354	2.263	508	6	100
	S	315	40	2	72	1.931				

Please consult with our technical department for different working conditions and design parameters.

Movements are non-concurrent

DESIGN VALUES

Bellows Material	304, 316, 321
Weld End Material	Carbon Steel, Stainless Steel
Design Pressure	6 barg
Design Temperature	400°C

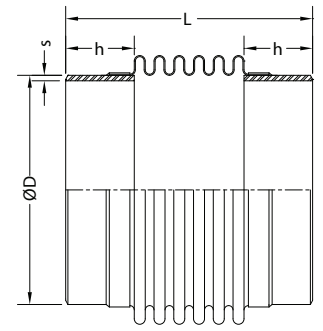

PN 6

DN	Type	Length (L) (mm)	Movements		Spring Rates		Effective Area (cm ²)	Weld-End		
			Axial (+/-) (mm)	Lateral (+/-) (mm)	Axial (N/mm)	Lateral (N/mm)		ØD (mm)	s (mm)	h (mm)
32	S	180	8	4,5	70	35	19	42,4	3	50
40	S	200	11	7	49	21	26	48,3	3	50
50	L	205	19	10	49	30	39	60,3	4	50
	S	156	10	3	92	189				
65	L	216	23	11	49	38	58	76,1	4	50
	S	180	16	5	71	112				
80	L	210	24	9	52	60	80	88,9	4	50
	S	174	17	4	75	181				
100	L	265	32	12	67	74	129	114,3	4	60
	S	210	25	6	49	132				
125	L	266	32	10	78	121	187	139,7	4	60
	S	194	20	3,5	73	404				
150	L	264	38	10	63	143	271	168,3	5	60
	S	196	20	3	115	879				
200	L	290	45	11,5	93	250	452	219,1	5	60
	S	210	28	3,5	102	895				
250	L	350	48	11	96	317	684	273	5	80
	S	250	30	3	104	1.380				
300	L	370	55	11,5	99	369	945	323,9	6	80
	S	270	32	3,5	159	1.984				
350	L	410	58	11	95	422	1.133	355,6	6	100
	S	310	32	3,5	170	2.533				
400	L	400	58	9,5	97	604	1.478	406,4	6	100
	S	320	38	4	139	2.257				
450	L	420	60	10	105	681	1.839	457,2	6	100
	S	320	36	3	170	3.419				
500	L	420	65	10	93	743	2.263	508	6	100
	S	320	35	3	167	4.132				

Please consult with our technical department for different working conditions and design parameters.

Movements are non-concurrent

DESIGN VALUES

Bellows Material	304, 316, 321
Weld End Material	Carbon Steel, Stainless Steel
Design Pressure	10 barg
Design Temperature	400°C

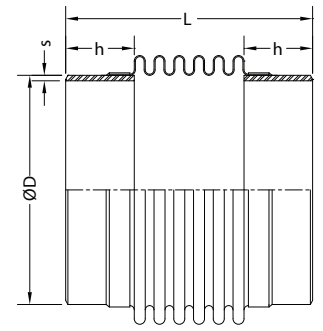

PN 10

DN	Type	Length (L) (mm)	Movements		Spring Rates		Effective Area (cm ²)	Weld-End		
			Axial (+/-) (mm)	Lateral (+/-) (mm)	Axial (N/mm)	Lateral (N/mm)		ØD (mm)	s (mm)	h (mm)
32	S	180	8	4,5	64	33	19	42,4	3	50
40	S	180	9	4,5	57	37	26	48,3	3	50
50	S	180	15	6	61	64	39	60,3	4	50
65	S	190	17	6	64	81	58	76,1	4	50
80	L	234	22	10	94	74	80	88,9	4	50
	S	184	18	5,5	65	125				
100	L	240	24	7,5	89	139	129	114,3	5	60
	S	190	18	3,5	71	300				
125	L	250	26	7,5	99	190	187	139,7	5	60
	S	190	18	3	81	495				
150	L	250	27	6,5	100	271	271	168,3	5	60
	S	210	22	3,5	79	423				
200	L	270	35	8	116	396	452	219,1	5	60
	S	210	23	3	131	1.133				
250	L	330	40	8	122	494	684	273	6	80
	S	250	23	2,5	192	2.562				
300	L	340	44	8	126	624	945	323,9	6	80
	S	270	27	3	202	2.489				
350	L	390	45	7,5	158	859	1.133	355,6	6	100
	S	310	28	2,5	253	3.793				
400	L	400	50	8	152	954	1.478	406,4	8	100
	S	320	30	3	256	4.136				
450	L	430	50	8,5	165	991	1.839	457,2	8	100
	S	320	30	2,5	283	5.703				
500	L	430	50	7,5	191	1.393	2.263	508	8	100
	S	320	27	2	343	8.426				

Please consult with our technical department for different working conditions and design parameters.

Movements are non-concurrent

DESIGN VALUES

Bellows Material	304, 316, 321
Weld End Material	Carbon Steel, Stainless Steel
Design Pressure	16 barg
Design Temperature	400°C

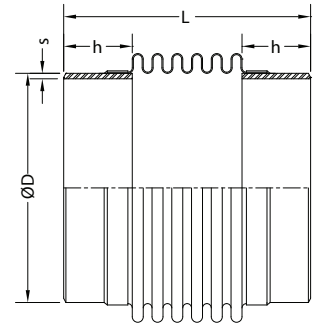

PN 16

DN	Type	Length (L) (mm)	Movements		Spring Rates		Effective Area (cm ²)	Weld-End		
			Axial (+/-) (mm)	Lateral (+/-) (mm)	Axial (N/mm)	Lateral (N/mm)		ØD (mm)	s (mm)	h (mm)
32	S	170	7	3,5	76	50	19	42,4	3	50
40	S	164	7	2,5	74	73	26	48,3	3	50
50	S	170	12	4	79	105	39	60,3	4	50
65	S	170	13	3,5	80	163	58	76,1	4	50
80	L	210	17	6,5	125	143	80	88,9	4	50
	S	160	12	2,5	99	353				
100	L	254	22	7,5	146	186	129	114,3	5	60
	S	220	19	5	113	249				
125	L	270	23	7,5	164	241	187	139,7	5	60
	S	220	21	4,5	114	363				
150	L	270	23	6,5	170	352	271	168,3	5	60
	S	200	15	2	180	1.217				
200	L	294	31	8	195	499	452	219,1	5	60
	S	210	18	2,5	255	2.208				
250	L	340	32	6,5	201	731	684	273	6	80
	S	250	18	2	343	4.557				
300	L	380	40	8,5	262	912	945	323,9	6	80
	S	280	22	2,5	472	5.103				
350	L	440	43	9	264	925	1.133	355,6	6	100
	S	320	22	2,5	513	6.592				
400	L	430	43	8	288	1.395	1.478	406,4	8	100
	S	324	24	2,5	519	7.948				
450	L	460	45	8,5	302	1.441	1.839	457,2	8	100
	S	324	22	2	604	11.529				
500	L	580	52	13	429	1.208	2.263	508	8	100
	S	360	23	2	1001	14.638				

Please consult with our technical department for different working conditions and design parameters.

Movements are non-concurrent

DESIGN VALUES

Bellows Material	304, 316, 321
Weld End Material	Carbon Steel, Stainless Steel
Design Pressure	25 barg
Design Temperature	400°C

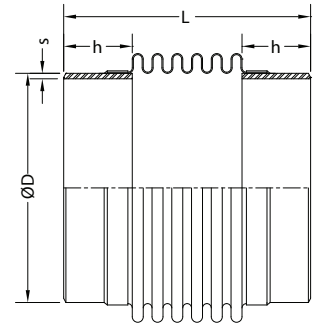

PN 25

DN	Type	Length (L) (mm)	Movements		Spring Rates		Effective Area (cm ²)	Weld-End		
			Axial (+/-) (mm)	Lateral (+/-) (mm)	Axial (N/mm)	Lateral (N/mm)		ØD (mm)	s (mm)	h (mm)
50	S	155	9	2,5	102	215	39	60,3	4	50
65	S	155	9	2	129	402	58	76,1	4	50
80	L	180	12	3	161	340	80	88,9	4	50
	S	155	8	1,5	226	955				
100	L	250	16	6	221	289	129	114,3	4	60
	S	200	11	2,5	276	923				
125	L	250	16	5	243	460	187	139,7	6	60
	S	200	11	2	326	1.569				
150	L	250	20	5	227	608	271	168,3	6	60
	S	215	15	3	263	1.284				
200	L	250	23	4,5	290	1.290	452	219,1	8	60
	S	225	19	3	354	2.348				
250	L	320	29	5,5	344	1.572	684	273	8	80
	S	270	20	2,5	6204	4.279				
300	L	340	32	5,5	507	2.588	975	323,9	8	80
	S	280	21	2,5	530	5.711				
350	L	400	36	6,5	480	1.391	1.161	355,6	8	100
	S	325	17	2	1199	14.065				
400	L	390	34	5	556	3.874	1.489	406,4	10	100
	S	330	24	2,5	778	10.975				
450	L	400	35	5	819	6.488	1.865	457,2	10	100
	S	340	22	2	992	15.450				
500	L	400	37	5	776	7.539	2.290	508	10	100
	S	340	25	2,5	1138	21.480				

Please consult with our technical department for different working conditions and design parameters.

Movements are non-concurrent

FLOATING FLANGED

Expansion Joints

Floating flanged type of expansion joints come with rotating (Vanstone) flange connections supplied in accordance with many industrial norms (ASME, EN, DIN, JIS, AS, BS) or special drillings. These units have rotating flanges on ends. This type of connection protects the flange from inside medium and minimizes flange bolt misalignments during installation of the expansion joint.

They are mainly used at lower pressure applications. This type is an excellent choice where inside medium is corrosive and use of a lower grade steel than bellows or piping can provide cost savings. With flanged type of connection, welding on site is not needed. They are not recommended where high pressures are present and leakage can be of concern.

This type expansion joints are commonly used at many industries and applications safely. They can be designed in single or universal expansion joint form depending on design conditions.

Applications

- » District heating
- » Steam lines
- » Chemical and process industries
- » Steel and iron industries
- » Pulp and paper industry
- » Water (hot and cold) lines
- » Marine applications, exhaust systems
- » Geothermal applications

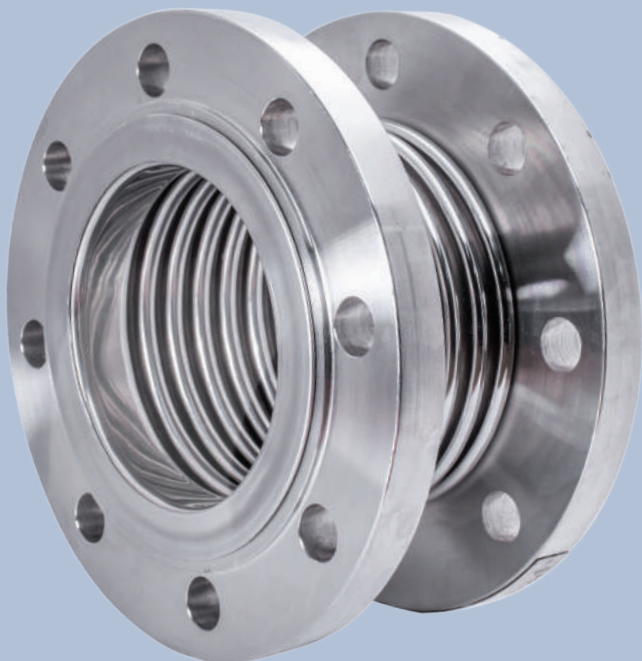

DESIGN VALUES

Bellows Material	304, 316, 321
Flange Material	Carbon Steel, Stainless Steel
Flange Norms	EN 1092, ANSI B16.5, JIS
Design Pressure	2.5 barg
Design Temperature	550°C

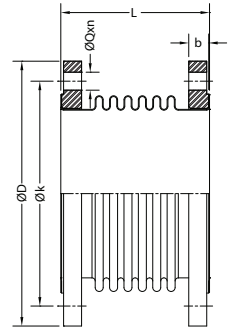

PN 2,5

DN	Type	Length (L) (mm)	Movements		Spring Rates		Effective Area (cm ²)	PN 2,5				
			Axial (+/-) (mm)	Lateral (+/-) (mm)	Axial (N/mm)	Lateral (N/mm)		ØD (mm)	Øk (mm)	b (mm)	n	ØQ (mm)
32	L	210	16	17	31	4	18	120	90	14	4	14
	S	140	8	5	57	26						
40	L	210	18	17	27	5	23	130	100	14	4	14
	S	140	10	5	50	29						
50	L	210	29	22	30	9	37	140	110	14	4	14
	S	160	20	10	44	27						
65	L	215	33	21	32	13	58	160	130	14	4	14
	S	160	22	9	48	45						
80	L	240	40	22	27	14	79	190	150	16	4	18
	S	180	24	9	46	58						
100	L	250	35	16	60	45	128	210	170	16	4	18
	S	180	23	6	82	166						
125	L	265	36	15	67	66	187	240	200	18	8	18
	S	195	26	7	85	202						
150	L	270	50	17	44	62	271	265	225	18	8	18
	S	195	30	6	65	274						
200	L	300	64	19	41	78	460	320	280	20	8	18
	S	200	40	6	58	389						
250	L	305	70	16	42	42	688	375	335	22	12	18
	S	205	40	5	68	683						
300	L	325	70	16	50	161	945	440	395	22	12	22
	S	205	40	4	78	1.076						
350	L	330	65	16	47	181	1.127	490	445	22	12	22
	S	200	35	3	102	1.993						
400	L	330	65	14	51	255	1.478	540	495	22	16	22
	S	205	30	2	65	1.507						
450	L	330	70	13	51	329	1.839	595	550	22	16	22
	S	210	35	2	80	2.001						
500	L	330	85	13	44	354	2.263	645	600	24	20	22
	S	225	40	2	72	1931						

Please consult with our technical department for different working conditions and design parameters.

Movements are non-concurrent

DESIGN VALUES

Bellows Material	304, 316, 321
Flange Material	Carbon Steel, Stainless Steel
Flange Norms	EN 1092, ANSI B16.5, JIS
Design Pressure	6 barg
Design Temperature	400°C

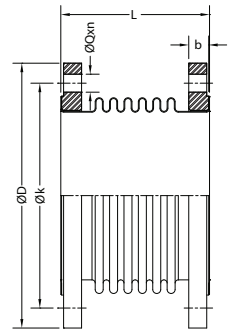

PN 6

DN	Type	Length (L) (mm)	Movements		Spring Rates		Effective Area (cm ²)	PN 6				
			Axial (+/-) (mm)	Lateral (+/-) (mm)	Axial (N/mm)	Lateral (N/mm)		ØD (mm)	Øk (mm)	b (mm)	n	ØQ (mm)
25	S	115	8	4,5	70	35	19	100	75	14	4	11
32	S	115	8	4,5	70	35	19	120	90	14	4	14
40	S	135	11	7	49	21	26	130	100	14	4	14
50	L	140	19	10	49	30	39	140	110	14	4	14
	S	90	10	3	92	189	39	140	110	14	4	14
65	L	155	23	11	49	38	58	160	130	14	4	14
	S	120	16	5	71	112	58	160	130	14	4	14
80	L	155	24	9	52	60	79	190	150	16	4	18
	S	120	17	4	75	181	79	190	150	16	4	18
100	L	225	32	12	67	74	130	210	170	16	4	18
	S	170	25	6	49	132	129	210	170	16	4	18
125	L	230	32	10	78	121	188	240	200	18	8	18
	S	160	20	3,5	73	404	187	240	200	18	8	18
150	L	230	38	10	63	143	271	265	225	18	8	18
	S	160	20	3	115	879	271	265	225	18	8	18
200	L	280	45	11,5	93	250	452	320	280	20	8	18
	S	200	28	3,5	102	895	452	320	280	20	8	18
250	L	300	48	11	96	317	684	375	335	22	12	18
	S	200	30	3	104	1.380	684	375	335	22	12	18
300	L	325	55	11,5	99	369	951	440	395	22	12	22
	S	225	32	3,5	159	1.984	956	440	395	22	12	22
350	L	325	58	11	95	422	1.142	490	445	22	12	22
	S	225	32	3,5	170	2.533	1.142	490	445	22	12	22
400	L	315	58	9,5	97	604	1.472	540	495	22	16	22
	S	235	38	4	139	2.257	1.479	540	495	22	16	22
450	L	335	60	10	105	681	1.832	595	550	22	16	22
	S	235	36	3	170	3.419	1.840	595	550	22	16	22
500	L	340	65	10	93	743	2.258	645	600	24	20	22
	S	240	35	3	167	4.132	2.258	645	600	24	20	22

Please consult with our technical department for different working conditions and design parameters.

Movements are non-concurrent

DESIGN VALUES

Bellows Material	304, 316, 321
Flange Material	Carbon Steel, Stainless Steel
Flange Norms	EN 1092, ANSI B16.5, JIS
Design Pressure	10 barg
Design Temperature	400°C

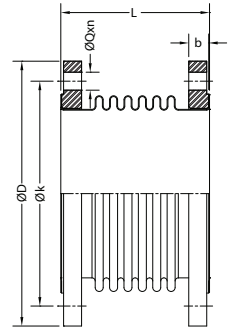

PN 10

DN	Type	Length (L) (mm)	Movements		Spring Rates		Effective Area (cm²)	PN 10				
			Axial (+/-) (mm)	Lateral (+/-) (mm)	Axial (N/mm)	Lateral (N/mm)		ØD (mm)	Øk (mm)	b (mm)	n	ØQ (mm)
25	S	125	8	4,5	64	33	19	115	85	18	4	14
32	S	125	8	4,5	64	33	19	140	100	18	4	18
40	S	125	9	4,5	57	37	26	150	110	18	4	18
50	S	125	15	6	61	64	39	165	125	18	4	18
65	S	140	17	6	64	81	58	185	145	18	8	18
80	L	190	22	10	94	74	80	200	160	20	8	18
	S	140	18	5,5	65	125	79	200	160	20	8	18
100	L	180	24	7,5	89	139	130	220	180	20	8	18
	S	125	18	3,5	71	300	129	220	180	20	8	18
125	L	190	26	7,5	99	190	187	250	210	22	8	18
	S	130	18	3	81	495	187	250	210	22	8	18
150	L	190	27	6,5	100	271	264	285	240	22	8	22
	S	150	22	3,5	79	423	259	285	240	22	8	22
200	L	255	35	8	116	396	452	340	295	24	8	22
	S	195	23	3	131	1.133	445	340	295	24	8	22
250	L	285	40	8	122	494	679	395	350	26	12	22
	S	205	23	2,5	192	2.562	684	395	350	26	12	22
300	L	300	44	8	126	624	948	445	400	26	12	22
	S	230	27	3	202	2.489	948	445	400	26	12	22
350	L	270	45	7,5	158	859	1.148	505	460	26	16	22
	S	190	28	2,5	253	3.793	1.148	505	460	26	16	22
400	L	280	50	8	152	954	1.477	565	515	26	16	26
	S	200	30	3	256	4.136	1.477	565	515	26	16	26
450	L	310	50	8,5	165	991	1.838	615	565	28	20	26
	S	200	30	2,5	283	5.703	1.845	615	565	28	20	26
500	L	310	50	7,5	191	1.393	2.245	670	620	28	20	26
	S	200	27	2	343	8.426	2.245	670	620	28	20	26
450	L	335	60	10	105	681	1.832	595	550	22	16	22
	S	235	36	3	170	3.419	1.840	595	550	22	16	22
500	L	340	65	10	93	743	2.258	645	600	24	20	22
	S	240	35	3	167	4.132	2.258	645	600	24	20	22

Please consult with our technical department for different working conditions and design parameters.
Movements are non-concurrent

DESIGN VALUES

Bellows Material	304, 316, 321
Flange Material	Carbon Steel, Stainless Steel
Flange Norms	EN 1092, ANSI B16.5, JIS
Design Pressure	16 barg
Design Temperature	400°C

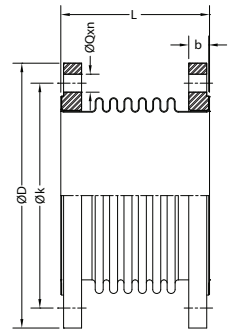

PN 16

DN	Type	Length (L) (mm)	Movements		Spring Rates		Effective Area (cm ²)	PN 16				
			Axial (+/-) (mm)	Lateral (+/-) (mm)	Axial (N/mm)	Lateral (N/mm)		ØD (mm)	Øk (mm)	b (mm)	n	ØQ (mm)
25	S	115	7	3,5	76	50	19	115	85	18	4	14
32	S	115	7	3,5	76	50	18	140	100	18	4	18
40	S	115	7	2,5	74	73	26	150	110	18	4	18
50	S	115	12	4	79	105	39	165	125	18	4	18
65	S	120	13	3,5	80	163	58	185	145	18	4	18
80	L	165	17	6,5	125	143	79	200	160	20	8	18
	S	120	12	2,5	99	353	79	200	160	20	8	18
100	L	190	22	7,5	146	186	130	220	180	20	8	18
	S	160	19	5	113	249	129	220	180	20	8	18
125	L	210	23	7,5	164	241	187	250	210	22	8	18
	S	160	21	4,5	114	363	188	250	210	22	8	18
150	L	210	23	6,5	170	352	263	285	240	22	8	22
	S	140	15	2	180	1.217	264	285	240	22	8	22
200	L	280	31	8	195	499	452	340	295	24	12	22
	S	200	18	2,5	255	2.208	445	340	295	24	12	22
250	L	310	32	6,5	201	731	680	405	355	26	12	26
	S	220	18	2	343	4.557	684	405	355	26	12	26
300	L	370	40	8,5	262	912	974	460	410	28	12	26
	S	270	22	2,5	472	5.103	972	460	410	28	12	26
350	L	330	43	9	264	925	1.155	520	470	30	16	26
	S	210	22	2,5	513	6.592	1.156	520	470	30	16	26
400	L	330	43	8	288	1.395	1.484	580	525	32	16	30
	S	220	24	2,5	519	7.948	1.484	580	525	32	16	30
450	L	360	45	8,5	302	1.441	1.849	640	585	34	20	30
	S	220	22	2	604	11.529	1.851	640	585	34	20	30
500	L	480	52	13	429	1.208	2.265	715	650	36	20	33
	S	260	23	2	1001	14.638	2.265	715	650	36	20	33

Please consult with our technical department for different working conditions and design parameters.

Movements are non-concurrent

DESIGN VALUES

Bellows Material	304, 316, 321
Flange Material	Carbon Steel, Stainless Steel
Flange Norms	EN 1092, ANSI B16.5, JIS
Design Pressure	25 barg
Design Temperature	400°C

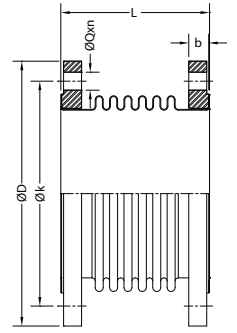

PN 25

DN	Type	Length (L) (mm)	Movements		Spring Rates		Effective Area (cm ²)	PN 25				
			Axial (+/-) (mm)	Lateral (+/-) (mm)	Axial (N/mm)	Lateral (N/mm)		ØD (mm)	Øk (mm)	b (mm)	n	ØQ (mm)
50	S	105	9	2,5	102	215	38	165	125	20	4	18
65	S	105	9	2	129	402	57	185	145	22	8	18
80	L	135	12	3	161	340	90	200	160	24	8	18
	S	110	8	1,5	226	955	77	200	160	24	8	18
100	L	185	16	6	221	289	129	235	190	24	8	22
	S	135	11	2,5	276	923	129	235	190	24	8	22
125	L	190	16	5	243	460	187	270	220	26	8	26
	S	140	11	2	326	1.569	187	270	220	26	8	26
150	L	195	20	5	227	608	258	300	250	28	8	26
	S	160	15	3	263	1.284	258	300	250	28	8	26
200	L	200	23	4,5	290	1.290	444	360	310	30	12	26
	S	175	19	3	354	2.348	444	360	310	30	12	26
250	L	235	29	5,5	344	1.572	682	425	370	32	12	30
	S	185	20	2,5	6204	4.279	682	425	370	32	12	30
300	L	260	32	5,5	507	2.588	975	485	430	34	16	30
	S	200	21	2,5	530	5.711	975	485	430	34	16	30
350	L	290	36	6,5	480	1.391	1.161	555	490	38	16	33
	S	215	17	2	1199	14.065	1.161	555	490	38	16	33
400	L	285	34	5	556	3.874	1.489	620	550	40	16	36
	S	225	24	2,5	778	10.975	1.489	620	550	40	16	36
450	L	305	35	5	819	6.488	1.865	670	600	46	20	36
	S	245	22	2	992	15.450	1.865	670	600	46	20	36
500	L	310	37	5	776	7.539	2.289	730	660	48	20	36
	S	250	25	2,5	1138	21.480	2.289	730	660	48	20	36

Please consult with our technical department for different working conditions and design parameters.

Movements are non-concurrent

FIXED FLANGED

Expansion Joints

Fixed flanged type of expansion joints come with fixed (welded) flange connections supplied in accordance with many industrial norms (ASME, EN, DIN, JIS, AS, BS) or special drillings. In these units, flanges are either welded to a pipe or bellows. They cannot rotate.

They are suitable for higher pressure applications than rotating flanges where sealing can be of concern. It is a good practice to select the flange material as the same steel grade of the piping. Installers should be careful about flange bolt misalignment for existing pipelines. Welding in field is not needed.

This type expansion joints are commonly used at many industries and applications safely. They can be designed in single or universal expansion joint form depending on design conditions.

Applications

- » District heating
- » Steam lines
- » Chemical and process industries
- » Steel and iron industries
- » Pulp and paper industry
- » Water (hot and cold) lines
- » Marine applications, exhaust systems
- » Geothermal applications

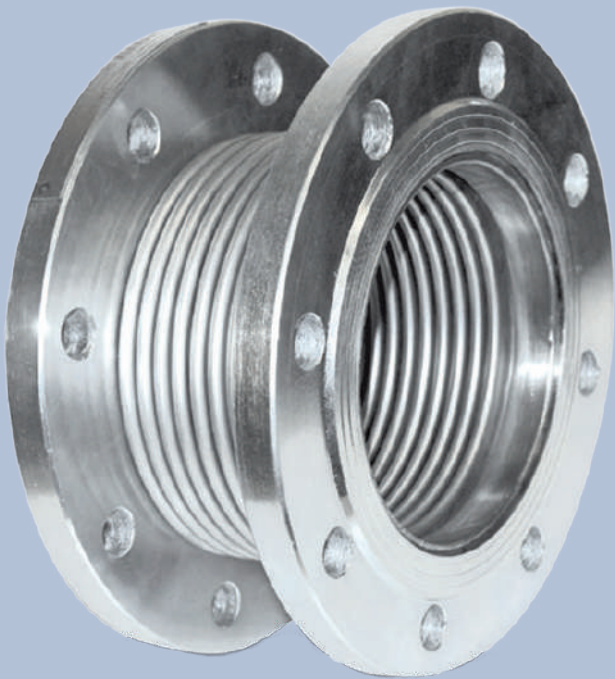

DESIGN VALUES

Bellows Material	304, 316, 321
Flange Material	Carbon Steel, Stainless Steel
Flange Norms	EN 1092, ANSI B16.5, JIS
Design Pressure	2,5 barg
Design Temperature	550°C

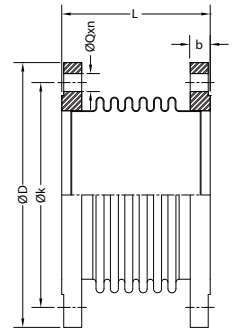

PN 2,5

DN	Type	Length (L) (mm)	Movements		Spring Rates		Effective Area (cm ²)	PN 2,5				
			Axial (+/-) (mm)	Lateral (+/-) (mm)	Axial (N/mm)	Lateral (N/mm)		ØD (mm)	Øk (mm)	b (mm)	n	ØQ (mm)
32	L	210	16	17	31	4	18	120	90	14	4	14
	S	140	8	5	57	26						
40	L	210	18	17	27	5	23	130	100	14	4	14
	S	140	10	5	50	29						
50	L	210	29	22	30	9	37	140	110	14	4	14
	S	160	20	10	44	27						
65	L	215	33	21	32	13	58	160	130	14	4	14
	S	160	22	9	48	45						
80	L	240	40	22	27	14	79	190	150	16	4	18
	S	180	24	9	46	58						
100	L	250	35	16	60	45	128	210	170	16	4	18
	S	180	23	6	82	166						
125	L	265	36	15	67	66	187	240	200	18	8	18
	S	195	26	7	85	202						
150	L	270	50	17	44	62	271	265	225	18	8	18
	S	195	30	6	65	274						
200	L	300	64	19	41	78	460	320	280	20	8	18
	S	200	40	6	58	389						
250	L	305	70	16	42	42	688	375	335	22	12	18
	S	205	40	5	68	683						
300	L	325	70	16	50	161	945	440	395	22	12	22
	S	205	40	4	78	1.076						
350	L	330	65	16	47	181	1.127	490	445	22	12	22
	S	200	35	3	102	1.993						
400	L	330	65	14	51	255	1.478	540	495	22	16	22
	S	205	30	2	65	1.507						
450	L	330	70	13	51	329	1.839	595	550	22	16	22
	S	210	35	2	80	2.001						
500	L	330	85	13	44	354	2.263	645	600	24	20	22
	S	225	40	2	72	1931						

Please consult with our technical department for different working conditions and design parameters.

Movements are non-concurrent

DESIGN VALUES

Bellows Material	304, 316, 321
Flange Material	Carbon Steel, Stainless Steel
Flange Norms	EN 1092, ANSI B16.5, JIS
Design Pressure	6 barg
Design Temperature	400°C

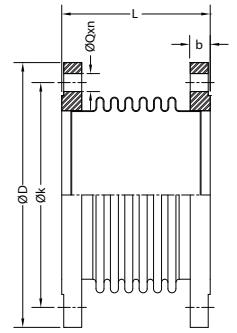

PN 6

DN	Type	Length (L) (mm)	Movements		Spring Rates		Effective Area (cm ²)	PN 6				
			Axial (+/-) (mm)	Lateral (+/-) (mm)	Axial (N/mm)	Lateral (N/mm)		ØD (mm)	Øk (mm)	b (mm)	n	ØQ (mm)
25	S	115	8	4,5	70	35	19	100	75	14	4	11
32	S	115	8	4,5	70	35	19	120	90	14	4	14
40	S	135	11	7	49	21	26	130	100	14	4	14
50	L	140	19	10	49	30	39	140	110	14	4	14
	S	90	10	3	92	189	39	140	110	14	4	14
65	L	155	23	11	49	38	58	160	130	14	4	14
	S	120	16	5	71	112	58	160	130	14	4	14
80	L	155	24	9	52	60	79	190	150	16	4	18
	S	120	17	4	75	181	79	190	150	16	4	18
100	L	225	32	12	67	74	130	210	170	16	4	18
	S	170	25	6	49	132	129	210	170	16	4	18
125	L	230	32	10	78	121	188	240	200	18	8	18
	S	160	20	3,5	73	404	187	240	200	18	8	18
150	L	230	38	10	63	143	271	265	225	18	8	18
	S	160	20	3	115	879	271	265	225	18	8	18
200	L	280	45	11,5	93	250	452	320	280	20	8	18
	S	200	28	3,5	102	895	452	320	280	20	8	18
250	L	300	48	11	96	317	684	375	335	22	12	18
	S	200	30	3	104	1.380	684	375	335	22	12	18
300	L	325	55	11,5	99	369	951	440	395	22	12	22
	S	225	32	3,5	159	1.984	956	440	395	22	12	22
350	L	325	58	11	95	422	1.142	490	445	22	12	22
	S	225	32	3,5	170	2.533	1.142	490	445	22	12	22
400	L	315	58	9,5	97	604	1.472	540	495	22	16	22
	S	235	38	4	139	2.257	1.479	540	495	22	16	22
450	L	335	60	10	105	681	1.832	595	550	22	16	22
	S	235	36	3	170	3.419	1.840	595	550	22	16	22
500	L	340	65	10	93	743	2.258	645	600	24	20	22
	S	240	35	3	167	4.132	2.258	645	600	24	20	22

Please consult with our technical department for different working conditions and design parameters.

Movements are non-concurrent

DESIGN VALUES

Bellows Material	304, 316, 321
Flange Material	Carbon Steel, Stainless Steel
Flange Norms	EN 1092, ANSI B16.5, JIS
Design Pressure	10 barg
Design Temperature	400°C

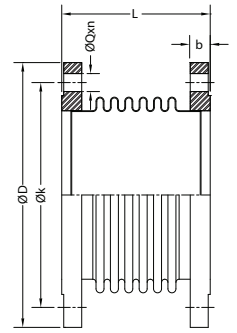

PN 10

DN	Type	Length (L) (mm)	Movements		Spring Rates		Effective Area (cm ²)	PN 10				
			Axial (+/-) (mm)	Lateral (+/-) (mm)	Axial (N/mm)	Lateral (N/mm)		ØD (mm)	Øk (mm)	b (mm)	n	ØQ (mm)
25	S	125	8	4,5	64	33	19	115	85	18	4	14
32	S	125	8	4,5	64	33	19	140	100	18	4	18
40	S	125	9	4,5	57	37	26	150	110	18	4	18
50	S	125	15	6	61	64	39	165	125	18	4	18
65	S	140	17	6	64	81	58	185	145	18	8	18
80	L	190	22	10	94	74	80	200	160	20	8	18
	S	140	18	5,5	65	125	79	200	160	20	8	18
100	L	180	24	7,5	89	139	130	220	180	20	8	18
	S	125	18	3,5	71	300	129	220	180	20	8	18
125	L	190	26	7,5	99	190	187	250	210	22	8	18
	S	130	18	3	81	495	187	250	210	22	8	18
150	L	190	27	6,5	100	271	264	285	240	22	8	22
	S	150	22	3,5	79	423	259	285	240	22	8	22
200	L	255	35	8	116	396	452	340	295	24	8	22
	S	195	23	3	131	1.133	445	340	295	24	8	22
250	L	285	40	8	122	494	679	395	350	26	12	22
	S	205	23	2,5	192	2.562	684	395	350	26	12	22
300	L	300	44	8	126	624	948	445	400	26	12	22
	S	230	27	3	202	2.489	948	445	400	26	12	22
350	L	270	45	7,5	158	859	1.148	505	460	26	16	22
	S	190	28	2,5	253	3.793	1.148	505	460	26	16	22
400	L	280	50	8	152	954	1.477	565	515	26	16	26
	S	200	30	3	256	4.136	1.477	565	515	26	16	26
450	L	310	50	8,5	165	991	1.838	615	565	28	20	26
	S	200	30	2,5	283	5.703	1.845	615	565	28	20	26
500	L	310	50	7,5	191	1.393	2.245	670	620	28	20	26
	S	200	27	2	343	8.426	2.245	670	620	28	20	26
450	L	335	60	10	105	681	1.832	595	550	22	16	22
	S	235	36	3	170	3.419	1.840	595	550	22	16	22
500	L	340	65	10	93	743	2.258	645	600	24	20	22
	S	240	35	3	167	4.132	2.258	645	600	24	20	22

Please consult with our technical department for different working conditions and design parameters.
Movements are non-concurrent

DESIGN VALUES

Bellows Material	304, 316, 321
Flange Material	Carbon Steel, Stainless Steel
Flange Norms	EN 1092, ANSI B16.5, JIS
Design Pressure	16 barg
Design Temperature	400°C

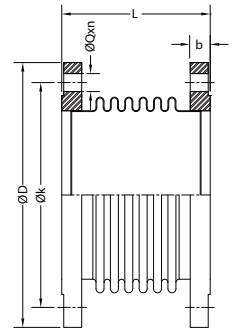

PN 16

DN	Type	Length (L) (mm)	Movements		Spring Rates		Effective Area (cm ²)	PN 16				
			Axial (+/-) (mm)	Lateral (+/-) (mm)	Axial (N/mm)	Lateral (N/mm)		ØD (mm)	Øk (mm)	b (mm)	n	ØQ (mm)
25	S	115	7	3,5	76	50	19	115	85	18	4	14
32	S	115	7	3,5	76	50	18	140	100	18	4	18
40	S	115	7	2,5	74	73	26	150	110	18	4	18
50	S	115	12	4	79	105	39	165	125	18	4	18
65	S	120	13	3,5	80	163	58	185	145	18	4	18
80	L	165	17	6,5	125	143	79	200	160	20	8	18
	S	120	12	2,5	99	353	79	200	160	20	8	18
100	L	190	22	7,5	146	186	130	220	180	20	8	18
	S	160	19	5	113	249	129	220	180	20	8	18
125	L	210	23	7,5	164	241	187	250	210	22	8	18
	S	160	21	4,5	114	363	188	250	210	22	8	18
150	L	210	23	6,5	170	352	263	285	240	22	8	22
	S	140	15	2	180	1.217	264	285	240	22	8	22
200	L	280	31	8	195	499	452	340	295	24	12	22
	S	200	18	2,5	255	2.208	445	340	295	24	12	22
250	L	310	32	6,5	201	731	680	405	355	26	12	26
	S	220	18	2	343	4.557	684	405	355	26	12	26
300	L	370	40	8,5	262	912	974	460	410	28	12	26
	S	270	22	2,5	472	5.103	972	460	410	28	12	26
350	L	330	43	9	264	925	1.155	520	470	30	16	26
	S	210	22	2,5	513	6.592	1.156	520	470	30	16	26
400	L	330	43	8	288	1.395	1.484	580	525	32	16	30
	S	220	24	2,5	519	7.948	1.484	580	525	32	16	30
450	L	360	45	8,5	302	1.441	1.849	640	585	34	20	30
	S	220	22	2	604	11.529	1.851	640	585	34	20	30
500	L	480	52	13	429	1.208	2.265	715	650	36	20	33
	S	260	23	2	1001	14.638	2.265	715	650	36	20	33

Please consult with our technical department for different working conditions and design parameters.

Movements are non-concurrent

DESIGN VALUES

Bellows Material	304, 316, 321
Flange Material	Carbon Steel, Stainless Steel
Flange Norms	EN 1092, ANSI B16.5, JIS
Design Pressure	25 barg
Design Temperature	400°C

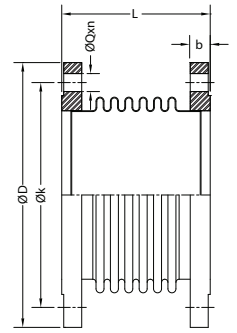

PN 25

DN	Type	Length (L) (mm)	Movements		Spring Rates		Effective Area (cm ²)	PN 25				
			Axial (+/-) (mm)	Lateral (+/-) (mm)	Axial (N/mm)	Lateral (N/mm)		ØD (mm)	Øk (mm)	b (mm)	n	ØQ (mm)
50	S	105	9	2,5	102	215	38	165	125	20	4	18
65	S	105	9	2	129	402	57	185	145	22	8	18
80	L	135	12	3	161	340	90	200	160	24	8	18
	S	110	8	1,5	226	955	77	200	160	24	8	18
100	L	185	16	6	221	289	129	235	190	24	8	22
	S	135	11	2,5	276	923	129	235	190	24	8	22
125	L	190	16	5	243	460	187	270	220	26	8	26
	S	140	11	2	326	1.569	187	270	220	26	8	26
150	L	195	20	5	227	608	258	300	250	28	8	26
	S	160	15	3	263	1.284	258	300	250	28	8	26
200	L	200	23	4,5	290	1.290	444	360	310	30	12	26
	S	175	19	3	354	2.348	444	360	310	30	12	26
250	L	235	29	5,5	344	1.572	682	425	370	32	12	30
	S	185	20	2,5	6204	4.279	682	425	370	32	12	30
300	L	260	32	5,5	507	2.588	975	485	430	34	16	30
	S	200	21	2,5	530	5.711	975	485	430	34	16	30
350	L	290	36	6,5	480	1.391	1.161	555	490	38	16	33
	S	215	17	2	1199	14.065	1.161	555	490	38	16	33
400	L	285	34	5	556	3.874	1.489	620	550	40	16	36
	S	225	24	2,5	778	10.975	1.489	620	550	40	16	36
450	L	305	35	5	819	6.488	1.865	670	600	46	20	36
	S	245	22	2	992	15.450	1.865	670	600	46	20	36
500	L	310	37	5	776	7.539	2.289	730	660	48	20	36
	S	250	25	2,5	1138	21.480	2.289	730	660	48	20	36

Please consult with our technical department for different working conditions and design parameters.

Movements are non-concurrent

RUBBER

Expansion Joints

One of the flexible products in KLINGER Turkey's portfolio is rubber expansion joints. With their body manufactured from EPDM, NBR, CR, SBR they provide excellent flexibility in short lengths. Flanges manufactured from various grades of carbon and stainless steel and cast iron in accordance with various industry standards.

Up to 110 degC working temperatures and 16 barg working pressures rubber expansion joints are used in a variety of applications especially to absorb vibrations.

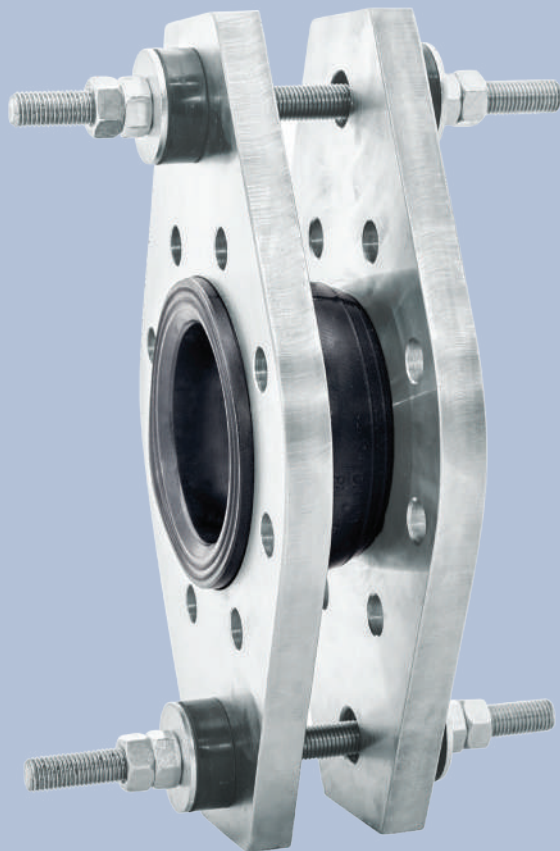

Rubber expansion joints are relatively low cost, low weight and can be supplied relatively fast since they are standard products. No gasket is required during the installation since rubber body acts as a gasket. Due to its inherent material properties rubber expansion joints are good at absorbing shock movements and all three types of movements (axial, lateral, angular) can be absorbed.

Rubber body is typically reinforced with nylon-cord keeping its flexibility.

KLINGER Turkey also provides tie-rods with rubber expansion joints upon request. These rods limit the excessive movements and restrain the pressure thrust.

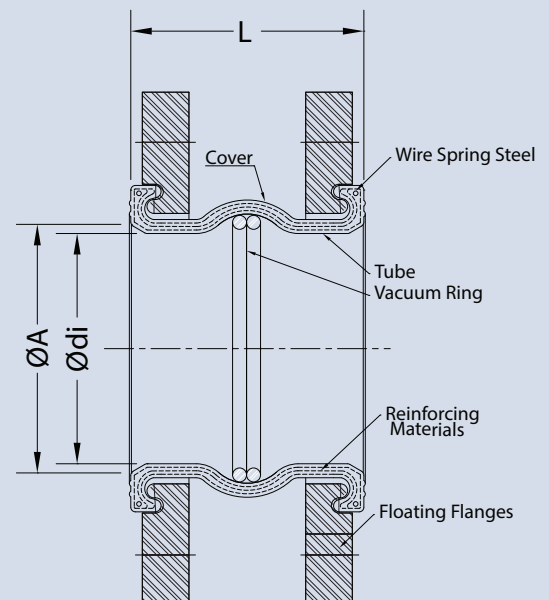

DESIGN VALUES

Body Material	EPDM, NBR, CR, SBR
Flange Material	Carbon Steel, Ductile Iron, Stainless Steel
Flange Norms	EN 1092, ANSI B16.5
Design Pressure	16 barg
Design Temperature	110°C

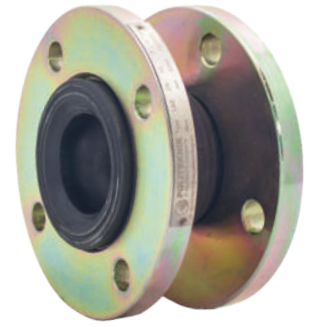

Applications

- » Pumps (suction and discharge)
- » Rotating equipment and machinery
- » HVAC industry
- » Sewage lines
- » Pulp and paper industry
- » Desalination plants
- » Marine industry
- » Chiller units

Flanges

Carbon steel and cast iron are used as standard. Flanges are also available in zinc plated or HDG carbon steel, stainless steel or etc. Flanges are drilled to EN 1092, ANSI B16.5, JIS, AWWA standards or any specific dimension.

Body Material

EPDM

Good for applications such as alkaline waste water and some chemical compounds except hydrocarbons. It is also resistant to ozone and corrosion. It has good heat resistance and electrical insulation properties.

NBR

Generally it has good resistance to hydrocarbons and oils. NBR bellows have good abrasion resistance compared to other rubber bellows. Typical application areas include oils, solvents, water and greases.

CR

It is known for good oil and grease resistance. CR has more resistance to ozone, weather and aging than natural rubber. It can be used at temperatures as low as -40 degC

SBR

It has good resistance for abrasive applications with good impact strength and resilience. It is known to be a polymer with good mechanical strength.

Tube	Reinforcing	Marketing Colour	Temperature Range	Permissible Operating Data			Hardness	Burst Pressure
EPDM	Nylon Cord C.	Red Point	-35 / +110 °C	16barg@50°C	10barg@70°C	6barg@90°C		
NBR	Nylon Cord C.	Yellow Point	-30 / +80 °C	16barg@30°C	10barg@50°C	6barg@70°C	60 ShoreA	45 barg
CR	Nylon Cord C.	Blue Point	-30/ +70 °C	16barg@30°C	10barg@50°C	6barg@70°C		

RUBBER

Expansion Joints

DN		L (Tolerance ± 5 mm)			Face of Bellows (Tolerance ± 3 mm)			Flange	Permissible Movements			
		Type A	Type B	Type C	\varnothing di	\varnothing A	\varnothing E	Thickness	Compression	Extension	Lateral	Angular
		mm	mm	mm	mm	mm	mm	mm	mm	mm	mm	deg.
25	1"	100	130	170	30	37	61	14	20	10	10	25
32	1 1/4"	100	130	150	37	51	75,5	14	20	10	10	25
40	1 1/2"	100	130	150	37	51	75,5	14	20	10	10	25
50	2"	100	130	150	50	60	86,5	15	20	10	10	25
65	2 1/2"	100	130	150	62	76	100	15	20	10	10	20
80	3"	100	130	150	78	91	117	17	20	10	10	20
100	4"	100	130	150	100	112	139	17	20	10	10	15
125	5"	120	130	150	124	136	167	19	25	15	15	15
150	6"	120	130	150	150	161	197,5	19	25	15	15	10
200	8"	120	130	175	200	209	253	21	25	15	15	10
250	10"	130	250	100	253	262	310	23	30	15	15	5
300	12"	210	130	100	301	325	370	24	30	17	18	5
350	14"	210	230	160	355	380	435	26	30	17	18	4
400	16"	220	235	-	400	417	477	28	35	19	19	3,5
450	18"	220	250	-	450	474	533	28	35	20	19	3,2
500	20"	270	200	100	495	515	585	30	40	25	20	2,8
600	24"	300	-	-	595	615	685	30	48	27	20	2,5
700	28"	300	-	-	700	716	786	30	48	27	20	2,5

Please consult with our technical department for different working conditions and design parameters.

DESIGN VALUES

Body Material	EPDM, NBR, CR, SBR
Flange Material	Carbon Steel, Ductile Iron, Stainless Steel
Flange Norms	EN 1092, ANSI B16.5
Design Pressure	16 barg
Design Temperature	110°C

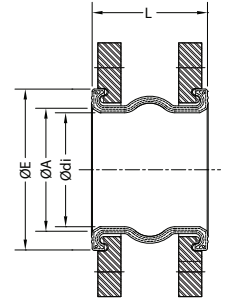

Effective Area	Max. Vacuum	Weight			Spring Rates			
	Without support Ring	wiht Flange S235JR Approx	with Flange GGG40 Approx.	as only Body Approx.	Axial Compression	Axial Extension	Lateral	Angular
cm ²	bar abs.	kg	kg	kg	N/mm	N/mm	N/mm	Nm/deg.
15	0,7	2,6	-	0,15	20	26	69	0,06
20	0,7	3	2,2	0,185	50	65	85	0,15
20	0,7	3,5	3	0,185	50	65	85	0,15
32	0,7	4	3,5	0,215	50	65	138	0,45
44	0,7	5	4,5	0,305	52	70	150	0,75
65	0,7	7	5	0,365	60	80	165	1,2
101	0,7	8	5,5	0,44	60	80	185	2,8
149	0,6	11	7,5	0,705	65	85	185	5
210	0,6	13,5	10	0,92	110	145	190	9
358	0,6	18,5	12,5	1,49	129	170	245	16
558	0,5	25,5	19,5	2,275	175	230	325	36
777	0,4	38	23,5	5,45	255	330	240	45
1109	0,4	52	-	6,4	280	360	290	60
1457	0,4	65	-	7,5	310	400	335	80
1815	0,4	74	-	8	340	450	380	118
2171	0,3	90	-	9	390	510	310	115
3155	0,2	140	-	15	470	600	370	230
4240	0,2	153	-	18	520	690	427	325

CENTRAL HEATING SYSTEM

Expansion Joints

This type of expansion joint is an excellent design for large displacements inside buildings. They have an outer cover for protection against external damage to bellows and for aesthetic looks. They also have an inner sleeve for a smooth medium flow internally.

Standard material of choice for bellows is 316/316L and balance of materials is carbon steel painted in white color. They are also available in all stainless steel form. They come with threaded connections up to DN65 and socket weld connections over DN65.

They can be axially pre-set for movements. Inner sleeve minimizes pressure loss and "whistling" due to flow. Installation is easy and quick. Typically one unit is sufficient for a 30 meter high building (about 10 story high residential building).

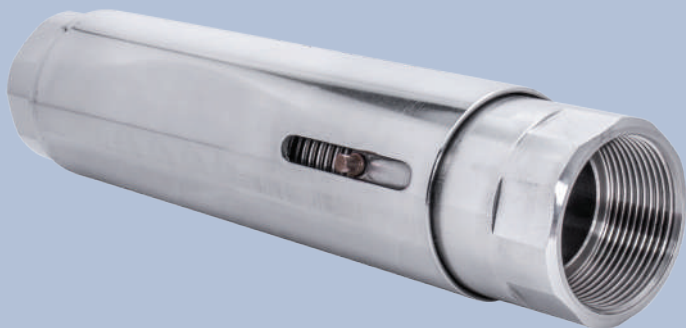
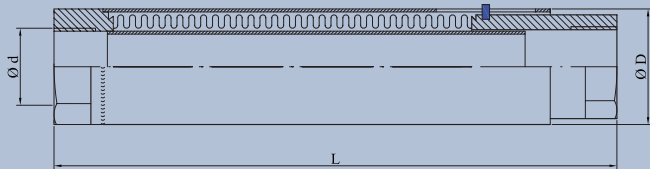

Applications

- » Central heating systems of buildings
- » Water pipe systems of large complexes such as shopping centers, hospitals, airports
- » Heating and ventilation systems

DESIGN VALUES

Bellows Material	304, 316, 321
Balance of Material	Carbon Steel, Stainless Steel
Design Pressure	16 barg
Design Temperature	400°C
Design Movement	Axial ± 25 mm

Nominal Diameter (DN)	DN15 (1/2")	DN20 (3/4")	DN25 (1")	DN32 (1 1/4")	DN40 (1 1/2")	DN50 (2")	DN65 (2 1/2")	DN80 (3")	DN100 (4")
Outside Diameter D (mm)	35	42	51	60	63	70	99	114	139
Length L (mm)	260	260	260	260	260	260	260	260	260

Above DN65, comes with "socket weld" connection. Please consult with our technical department for different working conditions and design parameters.

VIBRATION ABSORBER

Expansion Joints

Metal expansion joints can also be used to absorb vibration in systems. They are manufactured from thin, multi-layer bellows for excellent vibration absorbing capabilities. Multi-layer bellows help to dampen high frequency and low amplitude vibrations. While vibration absorbers are mostly used with flanged connections, they can also be supplied with welded connections.

A very typical accessory with this type of expansion joint is a limit rod / tie-rod to restrain pressure thrust of bellows or limit excessive design movements.

Metal expansion joints is an excellent choice for absorbing vibrations where temperatures or pressures are too high for rubber expansion joints. Rubber washers can be used to reduce noise.

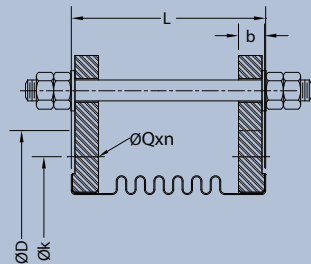

Applications

- » Pumps (suction or discharge)
- » Rotating machinery and equipment
- » Engines
- » Exhaust applications
- » Shipbuilding industry

DESIGN VALUES

Bellows Material	304, 316, 321
Balance of Material	Carbon Steel, Stainless Steel
Design Pressure	16 barg
Design Temperature	300°C

Nominal Diameter	Length (L) (mm)	Effective Area (cm ²)	Spring Rates		EN 1092				
			Axial (N/mm)	Lateral (N/mm)	ØD (mm)	Øk (mm)	b (mm)	n	ØQ (mm)
50	130	37	88	102	165	125	16	4	18
65	130	57	94	149	185	145	16	4	18
80	130	79	85	234	200	160	18	8	18
100	130	131	105	292	220	180	18	8	18
125	130	186	148	745	250	210	20	8	18
150	130	269	217	1.544	285	240	20	8	22
200	130	443	260	2.909	340	295	22	12	22
250	160	664	282	3.130	405	355	24	12	26
300	210	942	313	2.498	460	410	26	12	26
350	210	1143	529	5.138	520	470	28	16	26
400	220	1484	371	2.878	580	525	30	16	30
450	220	1845	530	7.196	640	585	32	20	30
500	270	2262	450	5.331	715	650	34	20	33

Please consult with our technical department for different working conditions and design parameters.

EXTERNALLY PRESSURIZED

Expansion Joints

Externally pressurized expansion joints is an excellent answer for large axial displacement needs. When large displacements are present in a system, more convolutions are needed to handle these large axial movements. Then, designing the bellows becomes a challenge for the expansion joint engineer due to “column squirm” (instability due to internal pressure / buckling of bellows) concerns. Solution to this challenge is to pressurize the “bellows” externally.

These units are very robust and safe. They have an in-built (part of the design) inner sleeve and outer cover. Outer cover protects the bellows from external damages during shipping, installation and operation. It also makes this unit suitable for underground usage. Inner sleeve provides smooth flow and prevents pressure losses.

These units are not suitable for lateral movements.

They can be provided with pipe ends or welded / rotating flange connections supplied in accordance with many industrial norms or special drillings.

Applications

- » City district heating
- » Steam and condensate lines
- » Superheated water
- » HVAC applications
- » Chemical and process industries
- » Pulp and paper industry
- » Geothermal applications



DESIGN VALUES

DN	25-1000
Bellows Material	304, 316, 321
Balance of Material	Carbon Steel, Stainless Steel
Design Pressure	up to 40 barg
Design Temperature	up to 400°C

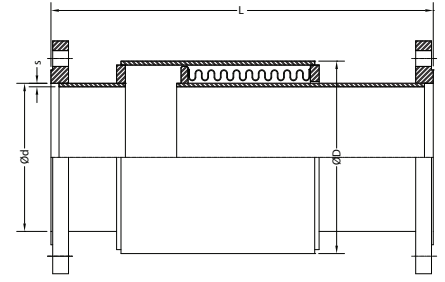

Flanged End

Nominal Diameter (DN)	Design Pressure (barg)	Axial (-) (mm) Length (L) (mm)				Ød (mm)	s (mm)	ØD (mm)	Effective Area (cm²)
		30	60	90	120				
25 1"	40	275	395	520	-	33,7	2,6	88,9	54
32 1 1/4"	40	285	405	530	-	42,4	3,2	88,9	54
40 1 1/2"	40	295	415	535	-	48,3	3,2	88,9	54
50 2"	40	300	420	555	710	60,3	3,6	114,3	89
65 2 1/2"	40	315	430	560	715	76,1	3,6	114,3	91
80 3"	25	315	435	585	725	88,9	4,0	139,7	141
100 4"	25	320	450	585	750	114,3	4,5	165,0	196
125 5"	25	335	465	595	765	139,7	5,0	193,7	272
150 6"	25	345	475	615	790	165,0	5,0	219,1	346
200 8"	25	395	520	685	860	219,1	4,5	323,9	572
250 10"	25	420	585	760	950	273,0	5,6	355,6	829

Weld End

Nominal Diameter (DN)	Design Pressure (barg)	Axial (-) (mm) Length (L) (mm)				Ød (mm)	s (mm)	ØD (mm)	Effective Area (cm²)
		30	60	90	120				
25 1"	40	275	395	520	-	33,7	2,6	88,9	54
32 1 1/4"	40	285	405	530	-	42,4	3,2	88,9	54
40 1 1/2"	40	295	415	535	-	48,3	3,2	88,9	54
50 2"	40	300	420	555	710	60,3	3,6	114,3	89
65 2 1/2"	40	315	430	560	715	76,1	3,6	114,3	91
80 3"	25	315	435	585	725	88,9	4,0	139,7	141
100 4"	25	320	450	585	750	114,3	4,5	165,0	196
125 5"	25	335	465	595	765	139,7	5,0	193,7	272
150 6"	25	345	475	615	790	165,0	5,0	219,1	346
200 8"	25	395	520	685	860	219,1	4,5	323,9	572
250 10"	25	420	585	760	950	273,0	5,6	355,6	829

Please consult with our technical department for different working conditions and design parameters.

SEISMIC LIMIT ROD

Expansion Joints

Metal expansion joints can also be used to absorb movements in piping systems due to earthquakes, ground settlements or landslides. These events can cause large movements in piping systems and cause critical piping systems to fail. Seismic expansion joints is an excellent choice for such applications. They are designed to absorb large axial and lateral movements.

Seismic expansion joints come with rods to limit excessive movements. They can have pipe ends, or welded / rotating flange connections supplied in accordance with many industrial norms or special drillings.

Applications

- » HVAC industry
- » Industrial applications
- » Hot and cold water pipelines
- » Firefighting systems
- » Steam and condensate lines

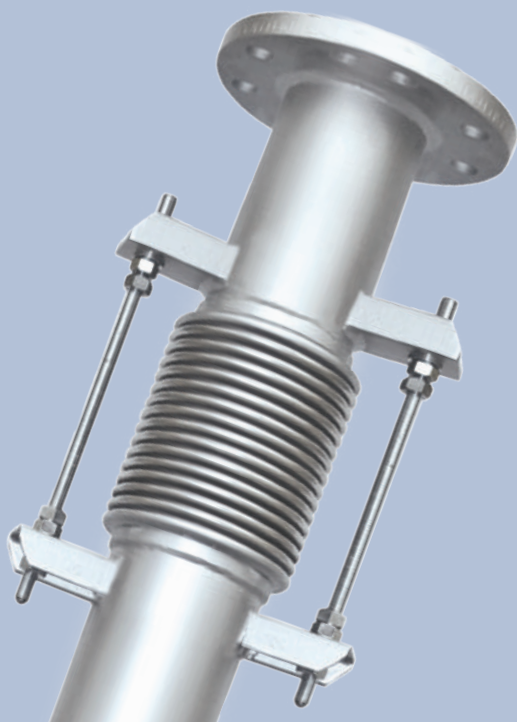

DESIGN VALUES

DN	32 – 250
Bellows Material	304, 316, 321
Balance of Material	Carbon Steel, Stainless Steel
Design Pressure	16 barg
Design Temperature	400°C

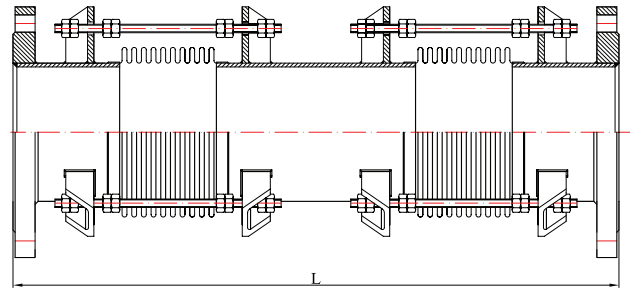

Nominal Diameter		Type 1			Type 2			Type 3		
		Movements (mm)		Length (L)	Movements (mm)		Length (L)	Movements (mm)		Length (L)
(DN)		Axial (+/-) (mm)	Lateral (+/-) (mm)	(mm)	Axial (+/-) (mm)	Lateral (+/-) (mm)	(mm)	Axial (+/-) (mm)	Lateral (+/-) (mm)	(mm)
32	1 1/4"	15	25	595	15	50	620	15	75	690
40	1 1/2"	15	25	620	15	50	650	15	75	720
50	2"	15	25	580	15	50	615	15	75	690
65	2 1/2"	15	25	620	15	50	660	15	75	735
		23	25	665	23	50	705	23	75	780
		30	25	710	30	50	750	30	75	825
80	3"	15	25	700	15	50	730	15	75	790
		23	25	750	23	50	780	23	75	835
		30	25	795	30	50	830	30	75	885
100	4"	15	25	750	15	50	790	15	75	825
		23	25	805	23	50	840	23	75	860
		30	25	860	30	50	895	30	75	915
125	5"	15	25	765	15	50	810	15	75	865
		23	25	810	23	50	875	23	75	910
		30	25	875	30	50	920	30	75	950
150	6"	15	25	840	15	50	890	15	75	945
		23	25	890	23	50	940	23	75	995
		30	25	940	30	50	985	30	75	1040
200	8"	15	25	885	15	50	960	15	75	1050
		23	25	935	23	50	1015	23	75	1100
		30	25	990	30	50	1065	30	75	1150
250	10"	15	25	885	15	50	930	15	75	1040
		23	25	930	23	50	985	23	75	1095
		30	25	985	30	50	1040	30	75	1150

Please consult with our technical department for different working conditions and design parameters.

Movements are non-concurrent

SEISMIC GIMBALS

Expansion Joints

Metal expansion joints can also be used to absorb movements in piping systems due to earthquakes, ground settlements or landslides. These events can cause large movements in piping systems and cause critical piping systems to fail. Seismic expansion joints is an excellent choice for such applications. They are designed to absorb large axial and lateral movements.

These seismic expansion joints come with gimbals to limit excessive movements. They can have pipe ends, or welded / rotating flange connections supplied in accordance with many industrial norms or special drillings.

Applications

- » HVAC industry
- » Industrial applications
- » Hot and cold water pipelines
- » Firefighting systems
- » Steam and condensate lines

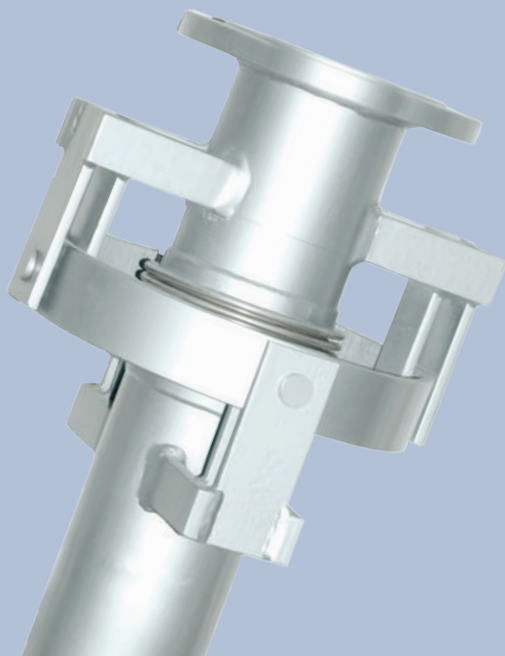

DESIGN VALUES

DN	32 – 250
Bellows Material	304, 316, 321
Balance of Material	Carbon Steel, Stainless Steel
Design Pressure	16 barg
Design Temperature	400°C

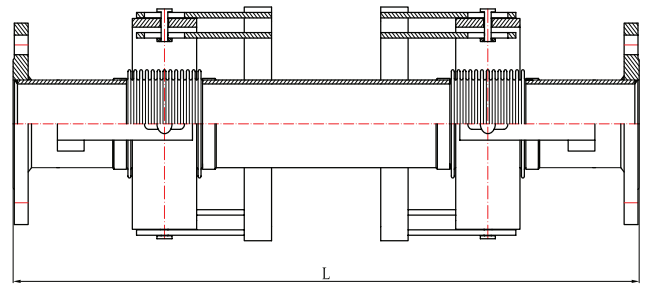

Nominal Diameter (DN)		Type 1				Type 2			
		Movements (mm)			Length (L)	Movements (mm)			Length (L)
		Axial x (+/-)	Lateral y (+/-)	Lateral z (+/-)	(mm)	Axial x (+/-)	Lateral y (+/-)	Lateral z (+/-)	(mm)
32	1 1/4"	50	100	100	750	50	200	200	750
40	1 1/2"	50	100	100	790	50	200	200	790
50	2"	50	100	100	790	50	200	200	790
65	2 1/2"	50	100	100	940	50	200	200	940
80	3"	50	100	100	940	50	200	200	940
100	4"	50	100	100	940	50	200	200	990
125	5"	50	100	100	940	50	200	200	1090
150	6"	50	100	100	1100	50	200	200	1200
200	8"	50	100	100	1130	50	200	200	1330
250	10"	50	100	100	1130	50	200	200	1430

Please consult with our technical department for different working conditions and design parameters.

Movements are non-concurrent

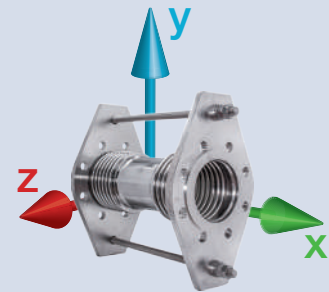

In addition to thermal movements in pipe lines, there are mechanical movements due to earthquakes, ground settlements and landslides. These type of movements can cause significant damage to the piping systems in dilatation points of buildings, pipe junctions between vessels and boilers.

These mechanical movements can be absorbed by using seismic expansion joints.

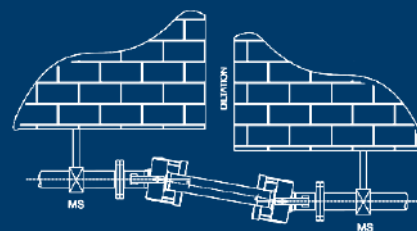
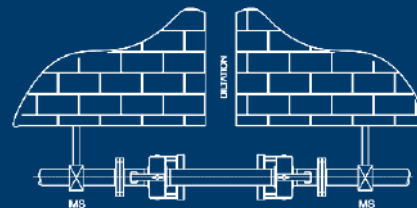

LENS

Expansion Joints

Lens bellows are manufactured from various grades of carbon and stainless steels, nickel alloys up to DN8000. Each convolution is manufactured individually and then welded circumferentially. They are single layer bellows and bellows thickness can be up to 6mm thick.

Applications include heat exchangers, large diameter piping systems, cement industries and chemical industries.

They have several advantages over U shape longitudinally welded thin bellows;

- » Thin walled bellows can easily be damaged during shipping, installation and operation causing stress risers ending up shortened bellows life or even failure. Since lens bellows are manufactured from thick materials, they are extremely durable and resistant to damage.
- » Their thicker walls allow using carbon steel materials and hold up to corrosion better than thin walled bellows
- » Drain couplings can be added at the lower extremities of convolutions to allow drainage
- » Weld repairs can be performed easily in field.
- » Very flexible manufacturing range due its manufacturing technique
- » They can be assembled in field.



DESIGN VALUES

DN	300-8000
Bellows Material	304, 316, 321, P265GH, 16Mo3, etc
Connection Material	Carbon Steel, Stainless Steel

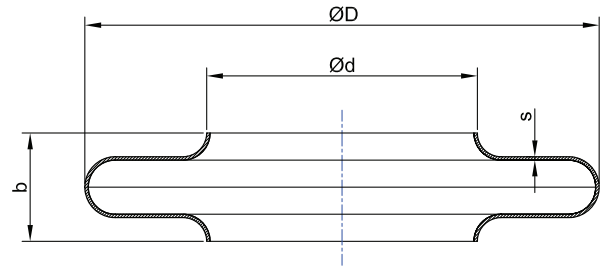

Nominal Diameter (DN)		Ød (mm)	ØD (mm)	b (mm)	Thickness (s) (mm)
300	12"	306	550	120-160	2-4
400	16"	408	700	120-160	2-4
500	20"	508	800	120-160	2-4
600	24"	610	900	120-160	2-4
700	28"	711	1000	120-160	2-4
800	32"	813	1100	120-160	2-4
900	36"	914	1200	120-160	2-4
1000	40"	1016	1300	120-160	2-4
1100	44"	1120	1480	160	2-4
1200	48"	1220	1580	160	2-4
1300	52"	1320	1680	160	2-4
1400	56"	1420	1780	160	2-4
1500	60"	1520	1880	160	2-4
1600	64"	1620	2020	160	2-4
1700	68"	1720	2120	160	2-4
1800	72"	1820	2220	160	2-4
1900	76"	1920	2320	160	2-4
2000	80"	2020	2500	160	2-6
2100	84"	2120	2600	160	2-6
2200	88"	2220	2700	160	2-6
2300	92"	2320	2800	160	2-6
2400	96"	2420	2900	160	2-6
2500	100"	2520	3000	160	2-6
2600	104"	2620	3100	160	2-6
2700	108"	2720	3200	160	2-6
2800	112"	2820	3300	160	2-6
2900	116"	2920	3400	160	2-6
3000	120"	3020	3500	160	2-6

Please consult with our technical department for different working conditions and design parameters.

RECTANGULAR

Expansion Joints

Rectangular expansion joints can be manufactured from various grades of carbon and stainless steels, nickel alloys custom designed for your needs. They are mostly for suitable for lower pressures and single layer bellows.

Various corner types are available while KLINGER Turkey specializes in straight corner and U shape convolution type.

They are most commonly used in ventilation systems, air ducts, HVAC applications, exhaust and fan systems. Typical industries include cement, power, gas turbines, chemical, steel and iron.

Rectangular expansion joints can also be supplied with inner sleeves to prevent bellows against abrasion and smooth the flow. Limit rods also can be supplied to prevent excessive movements.

These units can absorb movements all 3 movements (axial, lateral and angular)

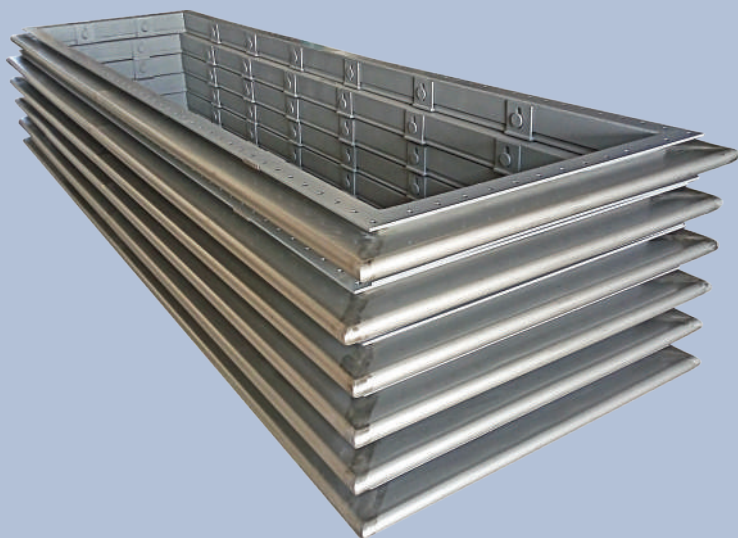

FABRIC

Expansion Joints

Fabric expansion joints are manufactured from several layers of specially selected fabric and insulation materials. These fabrics are usually laminated with special elastomers or fluoropolymers to enhance their resistance against chemicals and various environments. Insulation layer provides excellent resistance against very high temperatures.

These joints are ideal for low pressures and large diameters. They are extremely flexible and they have very low reaction forces to the piping system. They are highly customizable and this gives many options to the piping designers.

Other advantages they offer are; Good noise and vibration elimination properties, working temperatures up to 850 degC, very high flexibility at short spaces.

Fabric expansion joints are typically used in power plants, gas turbines, cement industries, chemical industries, steel and iron plants, process plants.

Inner sleeves can also be utilised to prevent abrasion of the layers and/or keep the insulation layer in place.

DESIGN VALUES

Design Pressure	up to 1 barg
Design Temperature	850°C



BALANCE I

Type Approved Expansion Joints

Type Approved standard expansion joints is a very important part of KLINGER Turkey's product portfolio. KLINGER Turkey has BV Type approved expansion joints in addition to its other quality certificates such as CE Module H, RMRS, ISO, EAC.

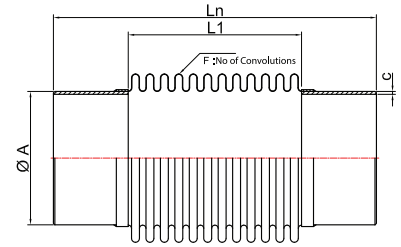

DESIGN VALUES

Bellows Material	304, 304L, 316, 316L, 321
Weld-End Material	Carbon Steel, Stainless Steel
Design Pressure	2,5 barg
Design Temperature	550°C
Drawing No	PT-001-BAL.0



**BUREAU
VERITAS**

Expansion joints DN450 through DN1000 have 1mm thick liners

Nominal Diameter	Length Range (Ln) (mm)		Movement		Bellows				Weld-Ends	
	Minimum Length	Maximum Length	Axial	Lateral	Number of Plies	Ply Thickness (mm)	Length of Bellows (L1)	Number of Convolutions (F)	ØA (mm)	c (mm)
DN32	205	315	28	15	1	0,3	105	26	42,4	2,6
DN40	205	315	28	15	1	0,3	105	22	48,3	2,6
DN50	245	360	28	15	2	0,3	120	13	60,3	2,9
DN65	245	360	28	14	2	0,3	120	13	76,1	2,9
DN80	245	360	28	13	2	0,3	120	13	88,9	3,2
DN90	245	360	35	10	2	0,3	120	13	101,6	3,2
DN100	245	360	35	10	2	0,3	120	12	114,3	3,6
DN125	245	360	35	9	2	0,3	120	11	139,7	3,6
DN150	245	360	35	9	2	0,3	120	11	168,3	4
DN175	245	360	35	9	2	0,3	120	9	193,7	4,5
DN200	245	360	35	6	2	0,3	120	9	219,1	4,5
DN250	245	360	35	5	2	0,3	120	9	273	5
DN300	295	440	40	6	2	0,3	145	9	323,9	5,6
DN350	295	440	40	5	2	0,3	145	9	355,6	5,6
DN400	295	440	40	4	2	0,3	145	9	406,4	5,6
DN450	300	500	45	4	2	0,4	176	8	457	8
DN500	340	550	45	4	2	0,4	216	9	508	8
DN550	340	550	45	4	2	0,4	216	9	559	8
DN600	340	550	45	4	2	0,4	216	9	609	10
DN650	340	550	45	4	2	0,4	216	9	660	10
DN700	380	590	45	4	2	0,4	168	6	711	10
DN750	380	590	45	4	2	0,4	168	6	762	10
DN800	380	590	45	4	2	0,4	180	6	812	10
DN850	380	590	45	4	2	0,5	180	6	863	10
DN900	380	590	45	4	2	0,5	170	5	914	10
DN950	380	590	45	4	2	0,5	170	5	965	10
DN1000	380	590	45	4	2	0,5	190	5	1016	10

BALANCE IF

Type Approved Expansion Joints

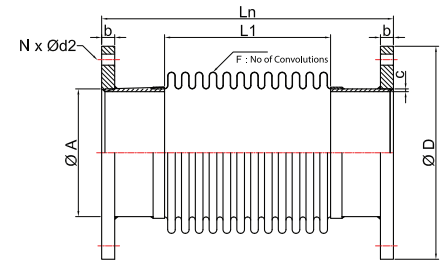

DESIGN VALUES

Bellows Material	304, 304L, 316, 316L, 321
Flange&Weld-End Material	Carbon Steel, Stainless Steel
Design Pressure	2,5 barg
Design Temperature	550°C
Drawing No	PT-007-BALF.0



**BUREAU
VERITAS**

Expansion joints DN450 through DN1000 have 1mm thick liners

Nominal Diameter	Length Range (L _n) (mm)		Movement		Bellows				Weld-Ends		Flange Dimension	
	Minimum Length	Maximum Length	Axial	Lateral	Number of Plies	Ply Thickness (mm)	Length of Bellows (L ₁)	Number of Convolutions (F)	ØA (mm)	c (mm)	Dimension (mm)	b (mm)
DN32	205	315	28	15	1	0,3	105	26	42,4	2,6		16
DN40	205	315	28	15	1	0,3	105	22	48,3	2,6		16
DN50	245	360	28	15	2	0,3	120	13	60,3	2,9		16
DN65	245	360	28	14	2	0,3	120	13	76,1	2,9		16
DN80	245	360	28	13	2	0,3	120	13	88,9	3,2		16
DN90	245	360	35	10	2	0,3	120	13	101,6	3,2		16
DN100	245	360	35	10	2	0,3	120	12	114,3	3,6		16
DN125	245	360	35	9	2	0,3	120	11	139,7	3,6		16
DN150	245	360	35	9	2	0,3	120	11	168,3	4		16
DN175	245	360	35	9	2	0,3	120	9	193,7	4,5		16
DN200	245	360	35	6	2	0,3	120	9	219,1	4,5		16
DN250	245	360	35	5	2	0,3	120	9	273	5	All dimensions out of thickness	16
DN300	295	440	40	6	2	0,3	145	9	323,9	5,6		16
DN350	295	440	40	5	2	0,3	145	9	355,6	5,6		16
DN400	295	440	40	4	2	0,3	145	9	406,4	5,6	Acc. to DIN 86 0 44 / EN 1092-1 / ASME B16.5	16
DN450	300	500	45	4	2	0,4	176	8	457	6		16
DN500	340	550	45	4	2	0,4	216	9	508	8		16
DN550	340	550	45	4	2	0,4	216	9	559	8		20
DN600	340	550	45	4	2	0,4	216	9	609	10		20
DN650	340	550	45	4	2	0,4	216	9	660	10		20
DN700	380	590	45	4	2	0,4	168	6	711	10		20
DN750	380	590	45	4	2	0,4	168	6	762	10		20
DN800	380	590	45	4	2	0,4	180	6	812	10		20
DN850	380	590	45	4	2	0,5	180	6	863	10		20
DN900	380	590	45	4	2	0,5	170	5	914	10		20
DN950	380	590	45	4	2	0,5	170	5	965	10		20
DN1000	380	590	45	4	2	0,5	190	5	1016	10		20

BALANCE II

Type Approved Expansion Joints

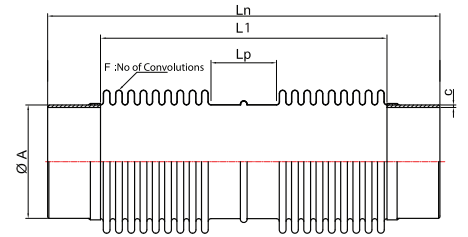

DESIGN VALUES

Bellows Material	304, 304L, 316, 316L, 321
Weld-End Material	Carbon Steel, Stainless Steel
Design Pressure	2,5 barg
Design Temperature	550°C
Drawing No	PT-002-BAL2.0



**BUREAU
VERITAS**

Nominal Diameter	Length Range (Ln) (mm)		Movement		Bellows					Weld-Ends	
	Minimum Length	Maximum Length	Axial	Lateral	Number of Plies	Ply Thickness (mm)	Length of Bellows (L1)	Length of Centerspool (LP)	Number of Convolutions (F)	ØA (mm)	c (mm)
DN40	375	415	30	73	1	0,3	295	101	20x2	48,3	2,6
DN50	375	415	32	65	2	0,3	295	100	17x2	60,3	2,9
DN65	345	415	54	54	2	0,3	265	111	11x2	76,1	3,2
DN80	380	420	38	63	2	0,3	300	115	13x2	88,9	3,2
DN90	330	420	36	46	2	0,3	250	113	9x2	101,6	3,2
DN100	330	420	36	46	2	0,3	250	113	9x2	114,3	3,6
DN125	320	420	32	33	2	0,3	240	100	9x2	139,7	3,6
DN150	395	475	45	46	2	0,3	295	107	10x2	168,3	4
DN175	395	475	44	40	2	0,3	295	107	10x2	193,7	4,5
DN200	405	485	49	42	2	0,3	305	116	8x2	219,1	4,5
DN250	405	485	47	33	2	0,3	305	116	7x2	273	5
DN300	415	500	50	26	2	0,3	275	88	6x2	323,9	5,6
DN350	415	500	50	24	2	0,3	275	88	6x2	355,6	5,6
DN400	485	570	73	42	2	0,3	345	115	6x2	406,4	5,6
DN450	490	570	71	37	2	0,4	350	120	5x2	457	6
DN500	460	570	62	26	2	0,4	320	115	5x2	508	6

BALANCE IIF

Type Approved Expansion Joints

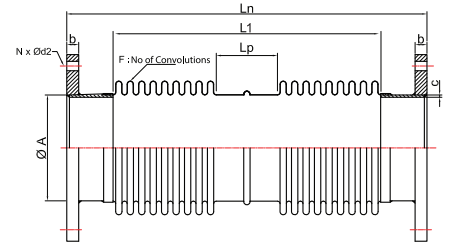

DESIGN VALUES

Bellows Material	304, 304L, 316, 316L, 321
Flange&Weld-End Material	Carbon Steel, Stainless Steel
Design Pressure	2,5 barg
Design Temperature	550°C
Drawing No	PT-008-BAL2F.0



**BUREAU
VERITAS**

Nominal Diameter	Length Range (L _n) (mm)		Movement		Bellows					Weld-Ends		Flange Dimension	
	Minimum Length	Maximum Length	Axial	Lateral	Number of Plies	Ply Thickness (mm)	Length of Bellows (L ₁)	Length of Centerspool (L _p)	Number of Convolutions (F)	ØA (mm)	c (mm)	Dimension (mm)	b (mm)
DN40	375	415	30	73	1	0,3	295	101	20x2	48,3	2,6		16
DN50	375	415	32	65	2	0,3	295	100	17x2	60,3	2,9		16
DN65	345	415	54	54	2	0,3	265	111	11x2	76,1	3,2		16
DN80	380	420	38	63	2	0,3	300	115	13x2	88,9	3,2		16
DN90	330	420	36	46	2	0,3	250	113	9x2	101,6	3,2		16
DN100	330	420	36	46	2	0,3	250	113	9x2	114,3	3,6	All dimensions out of thickness	16
DN125	320	420	32	33	2	0,3	240	100	9x2	139,7	3,6		16
DN150	395	475	45	46	2	0,3	295	107	10x2	168,3	4	Acc. to DIN 86 0 44 / EN 1092-1 / ASME B16.5	16
DN175	395	475	44	40	2	0,3	295	107	10x2	193,7	4,5		16
DN200	405	485	49	42	2	0,3	305	116	8x2	219,1	4,5		16
DN250	405	485	47	33	2	0,3	305	116	7x2	273	5		16
DN300	415	500	50	26	2	0,3	275	88	6x2	323,9	5,6		16
DN350	415	500	50	24	2	0,3	275	88	6x2	355,6	5,6		16
DN400	485	570	73	42	2	0,3	345	115	6x2	406,4	5,6		16
DN450	490	570	71	37	2	0,4	350	120	5x2	457	6		16
DN500	460	570	62	26	2	0,4	320	115	5x2	508	6		16

BALANCE III - IIIF

Type Approved Expansion Joints

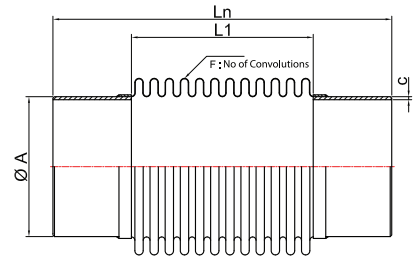

DESIGN VALUES

Bellows Material	304, 304L, 316, 316L, 321
Flange&Weld-End Material	Carbon Steel, Stainless Steel
Design Pressure	2,5 barg
Design Temperature	550°C
Drawing No	PT-003-BAL3.0 PT-009-BAL3F.0

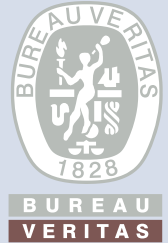

PT-003-BAL3.0

Nominal Diameter	Length Range (Ln) (mm)		Movement		Bellows				Weld-Ends	
	Minimum Length	Maximum Length	Axial	Lateral	Number of Plies	Ply Thickness (mm)	Length of Bellows (L1)	Number of Convolutions (F)	ØA (mm)	c (mm)
DN100	285	400	45	20	2	0,3	165	15	114,3	3,6
DN125	295	410	45	20	2	0,3	165	15	139,7	3,6
DN150	295	410	45	20	2	0,3	175	13	168,3	4
DN175	315	415	45	20	2	0,3	175	13	193,7	4,5
DN200	315	415	45	20	2	0,3	175	13	219,1	4,5
DN250	345	450	45	20	2	0,3	175	13	273	5
DN300	345	450	50	15	2	0,3	210	13	323,9	5,6
DN350	345	450	50	15	2	0,3	210	13	355,6	5,6

PT-009-BAL3F.0

Nominal Diameter	Length Range (Ln) (mm)		Movement		Bellows				Weld-Ends		Flange Dimension	
	Minimum Length	Maximum Length	Axial	Lateral	Number of Plies	Ply Thickness (mm)	Length of Bellows (L1)	Number of Convolutions (F)	ØA (mm)	c (mm)	Dimension (mm)	b (mm)
DN100	285	400	45	20	2	0,3	165	15	114,3	3,6	All dimensions out of thickness	16
DN125	295	410	45	20	2	0,3	165	15	139,7	3,6		16
DN150	295	410	45	20	2	0,3	175	13	168,3	4		16
DN175	315	415	45	20	2	0,3	175	13	193,7	4,5		16
DN200	315	415	45	20	2	0,3	175	13	219,1	4,5		16
DN250	345	450	45	20	2	0,3	175	13	273	5	Acc. to DIN 86 0 44 /	16
DN300	345	450	50	15	2	0,3	210	13	323,9	5,6	EN 1092-1 /	16
DN350	345	450	50	15	2	0,3	210	13	355,6	5,6	ASME B16.5	16

BALANCE IV - IVF

Type Approved Expansion Joints

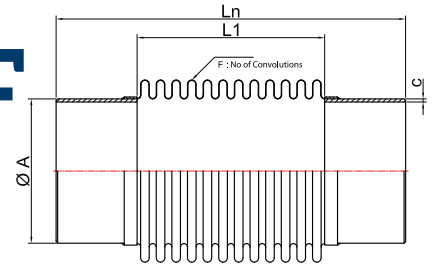

DESIGN VALUES

Bellows Material	304, 304L, 316, 316L, 321
Flange&Weld-End Material	Carbon Steel, Stainless Steel
Design Pressure	2,5 barg
Design Temperature	550°C
Drawing No	PT-004-BAL4.0 PT-010-BAL4F.0



PT-004-BAL4.0

Nominal Diameter	Length Range (Ln) (mm)		Movement		Bellows				Weld-Ends	
	Minimum Length	Maximum Length	Axial	Lateral	Number of Plies	Ply Thickness (mm)	Length of Bellows (L1)	Number of Convolutions (F)	ØA (mm)	c (mm)
DN40	150	250	25	8	2	0,3	90	18	48,3	2,6
DN50	150	250	25	8	2	0,3	90	10	60,3	2,9
DN65	150	250	25	8	2	0,3	90	10	76,1	2,9
DN80	150	250	25	8	2	0,3	90	10	88,9	3,2
DN90	150	250	25	6	2	0,3	77	7	101,6	3,2
DN100	150	275	25	6	2	0,3	77	7	114,3	3,6
DN125	150	275	25	5	2	0,3	77	6	139,7	3,6
DN150	150	300	25	5	2	0,3	80	6	168,3	4
DN175	150	300	25	5	2	0,3	80	6	193,7	4
DN200	150	300	25	5	2	0,3	80	6	219,1	4,5
DN250	150	315	25	4	2	0,3	80	6	273	5
DN300	150	315	25	4	2	0,3	80	5	323,9	5,6

PT-010-BAL4F.0

Nominal Diameter	Length Range (Ln) (mm)		Movement		Bellows				Weld-Ends		Flange Dimension	
	Minimum Length	Maximum Length	Axial	Lateral	Number of Plies	Ply Thickness (mm)	Length of Bellows (L1)	Number of Convolutions (F)	ØA (mm)	c (mm)	Dimension (mm)	b (mm)
DN40	150	250	25	8	2	0,3	90	18	48,3	2,6		16
DN50	150	250	25	8	2	0,3	90	10	60,3	2,9		16
DN65	150	250	25	8	2	0,3	90	10	76,1	2,9	All dimensions out of thickness	16
DN80	150	250	25	8	2	0,3	90	10	88,9	3,2		16
DN90	150	250	25	6	2	0,3	77	7	101,6	3,2		16
DN100	150	275	25	6	2	0,3	77	7	114,3	3,6		16
DN125	150	275	25	5	2	0,3	77	6	139,7	3,6		16
DN150	150	300	25	5	2	0,3	80	6	168,3	4	Acc. to DIN 86 0 44 / EN 1092-1 / ASME B16.5	16
DN175	150	300	25	5	2	0,3	80	6	193,7	4		16
DN200	150	300	25	5	2	0,3	80	6	219,1	4,5		16
DN250	150	315	25	4	2	0,3	80	6	273	5		16
DN300	150	315	25	4	2	0,3	80	5	323,9	5,6		16

BALANCE V

Type Approved Expansion Joints

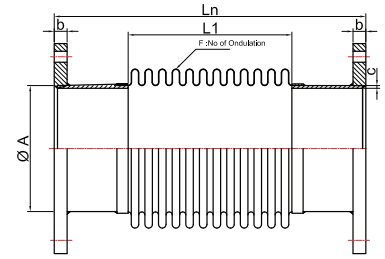

DESIGN VALUES

Bellows Material	304, 304L, 316, 316L, 321
Flange&Weld-End Material	Carbon Steel, Stainless Steel
Design Pressure	2,5 barg
Design Temperature	550°C
Drawing No	PT-005-BAL5.0



**BUREAU
VERITAS**

Nominal Diameter	Length Range (L _n) (mm)		Movement		Bellows				Weld-Ends		Flange Dimension
	Minimum Length	Maximum Length	Axial	Lateral	Number of Plies	Ply Thickness (mm)	Length of Bellows (L ₁)	Number of Convolutions (F)	ØA (mm)	c (mm)	Dimension (mm)
DN40	215	255	28	15	2	0,3	105	22	48,3	2,6	
DN50	255	270	28	15	2	0,3	120	13	60,3	2,9	
DN65	255	270	28	14	2	0,3	120	13	76,1	2,9	
DN80	255	270	28	13	2	0,3	120	13	88,9	3,2	
DN90	255	270	35	10	2	0,3	120	13	101,6	3,2	
DN100	255	270	35	10	2	0,3	120	11	114,3	3,6	All dimensions out of thickness
DN125	255	270	35	9	2	0,3	120	11	139,7	3,6	
DN150	255	270	35	9	2	0,3	120	9	168,3	4	Acc. To EN1092-1 / ASME B16.5 / ASME B16.47 / JIS
DN175	255	270	35	9	2	0,3	120	9	193,7	4,5	
DN200	255	270	35	6	2	0,3	120	9	219,1	4,5	
DN250	255	270	35	5	2	0,3	120	9	273	5	
DN300	305	460	40	6	2	0,3	145	9	323,9	5,6	
DN350	305	460	40	5	2	0,3	145	9	355,6	5,6	
DN400	305	460	40	4	2	0,3	145	9	406,4	5,6	
DN450	490	570	71	37	2	0,4	350	5x2	457	6	
DN500	460	570	62	26	2	0,4	320	5x2	508	6	

BALANCE VI

Type Approved Expansion Joints

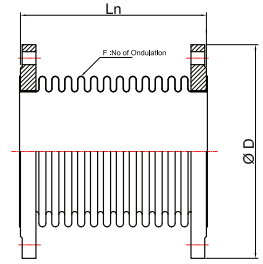

DESIGN VALUES

Bellows Material	304, 304L, 316, 316L, 321
Flange Material	Carbon Steel, Stainless Steel
Design Pressure	16 barg
Design Temperature	550°C
Drawing No	PT-006-BAL6.0



**BUREAU
VERITAS**

Nominal Diameter	Length (Ln) (mm)	Movement	Bellows				Flange Dimension
		Axial	Inside Diameter	Number of Plies	Ply Thickness (mm)	Number of Convolutions (F)	Dimension (mm)
DN40	130	30(±15)	48,3	1	0,3	20	Acc. to EN 1092-1 (PN10- PN16) / ASME B16.5 (150LB)
DN50	130	30(±15)	60,3	2	0,3	16	
DN65	130	30(±15)	76,1	2	0,3	14	
DN80	130	30(±15)	88,9	2	0,3	13	
DN100	130	30(±15)	114,3	2	0,3	12	
DN125	130	30(±15)	139,7	2	0,3	12	
DN150	130	30(±15)	168,3	2	0,4	12	
DN200	130	30(±15)	219,1	2	0,4	8	
DN250	130	30(±15)	273	2	0,4	7	
DN300	130	30(±15)	323,9	2	0,4	6	

RF 30-60 AXIAL

Type Approved Expansion Joints

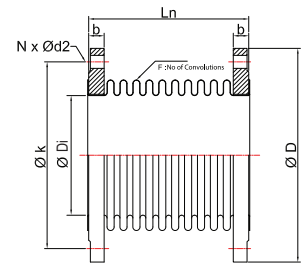

DESIGN VALUES

Bellows Material	304, 304L, 316, 316L, 321
Flange Material	Carbon Steel, Stainless Steel
Design Pressure	16 barg
Design Temperature	550°C
Connection Type	Rotating Flange
Drawing No	PT-011-RF30.0 PT-012-RF60.0

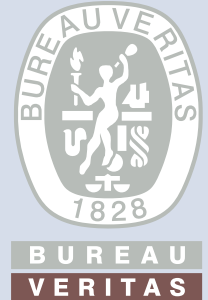

DESIGN NO: PT-011-RF30.0

Nominal Diameter	Length (Ln) (mm)	Movement		Bellows			Flange
		Axial	Inside Diameter	Number of Plies	Ply Thickness (mm)	Number of Convolutions (F)	Dimensions
DN40	120	30	48,3	1	0,3	18	Acc. to EN 1092-1 (PN10-PN16) / ASME B16.5 (150LB)
DN50	120	30	60,3	1	0,4	14	
DN65	120	30	76,1	1	0,4	12	
DN80	120	30	88,9	1	0,5	11	
DN100	120	30	114,3	1	0,5	10	
DN125	125	30	139,7	1	0,6	10	
DN150	130	30	168,3	1	0,6	10	
DN200	150	30	219,1	1	0,8	8	
DN250	165	30	273	1	0,8	8	
DN300	170	30	323,9	1	0,8	7	

DESIGN NO: PT-012-RF60.0

Nominal Diameter	Length (Ln) (mm)	Movement		Bellows			Flange
		Axial	Inside Diameter	Number of Plies	Ply Thickness (mm)	Number of Convolutions (F)	Dimensions
DN65	180	60	76,1	1	0,4	20	Acc. to EN 1092-1 (PN10-PN16) / ASME B16.5 (150LB)
DN80	180	60	88,9	1	0,5	19	
DN100	185	60	114,3	1	0,5	18	
DN125	190	60	139,7	1	0,6	18	
DN150	200	60	168,3	1	0,6	18	
DN200	230	60	219,1	1	0,8	14	
DN250	245	60	273	1	0,8	14	
DN300	250	60	323,9	1	0,8	12	

FF 30-60 AXIAL

Type Approved Expansion Joints

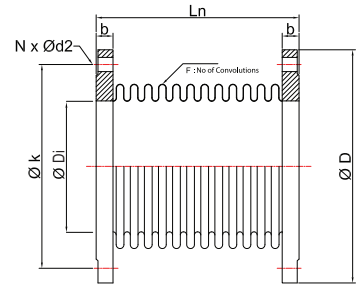

DESIGN VALUES

Bellows Material	304, 304L, 316, 316L, 321
Flange Material	Carbon Steel, Stainless Steel
Design Pressure	16 barg
Design Temperature	550°C
Connection Type	Fixed Flange
Drawing No	PT-013-FF30.0 PT-014-FF60.0

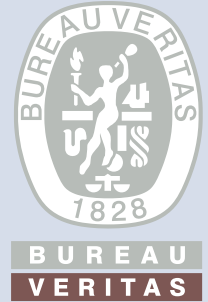

DESIGN NO: PT-013-FF30.0

Nominal Diameter	Length (Ln) (mm)	Movement		Bellows			Flange
		Axial	Inside Diameter	Number of Plies	Ply Thickness (mm)	Number of Convolutions (F)	Dimensions
DN40	120	30	48,3	1	0,3	18	Acc. to EN 1092-1 (PN10-PN16) / ASME B16.5 (150LB)
DN50	120	30	60,3	1	0,4	14	
DN65	120	30	76,1	1	0,4	12	
DN80	120	30	88,9	1	0,5	11	
DN100	120	30	114,3	1	0,5	10	
DN125	125	30	139,7	1	0,6	10	
DN150	130	30	168,3	1	0,6	10	
DN200	150	30	219,1	1	0,8	8	
DN250	165	30	273	1	0,8	8	
DN300	170	30	323,9	1	0,8	7	

DESIGN NO: PT-014-FF60.0

Nominal Diameter	Length (Ln) (mm)	Movement		Bellows			Flange
		Axial	Inside Diameter	Number of Plies	Ply Thickness (mm)	Number of Convolutions (F)	Dimensions
DN65	180	60	76,1	1	0,4	20	Acc. to EN 1092-1 (PN10-PN16) / ASME B16.5 (150LB)
DN80	180	60	88,9	1	0,5	19	
DN100	185	60	114,3	1	0,5	18	
DN125	190	60	139,7	1	0,6	18	
DN150	200	60	168,3	1	0,6	18	
DN200	230	60	219,1	1	0,8	14	
DN250	245	60	273	1	0,8	14	
DN300	250	60	323,9	1	0,8	12	

BALANCE VIII

Type Approved Expansion Joints

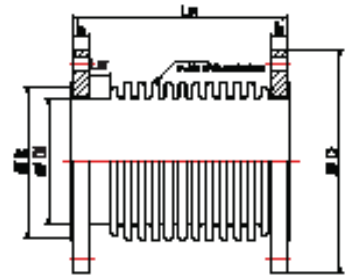

DESIGN VALUES

Bellows Material	304, 304L, 316, 316L, 321
Weld-End Material	Carbon Steel, Stainless Steel
Design Pressure	2,5 barg
Design Temperature	550°C
Drawing No	US1BU-03



**BUREAU
VERITAS**

Nominal Diameter	Length Range (Ln) (mm)		Ln (mm)	Lw (mm)	Bellows						Flange Dimension	
	Minimum Length	Maximum Length	Pre-set Length Range	Neck of Bellows Range	ØA	Number of Plies	Ply Thickness (mm)	Pitch	Convolution Height	Number of Convolution (F)	Dimension (mm)	b (mm)
DN80	180	210	200-230	0-15	-	2	0,3	8,5	10	16		20
DN100	150	180	170-300	0-15	-	2	0,3	8	13,5	14		20
DN125	185	225	210-250	0-20	-	2	0,3	11	14	13		22
DN150	200	255	225-280	0-25	-	2	0,3	12	14	13		22
DN175	205	255	230-280	0-25	-	2	0,3	12,3	15	13		22
DN200	185	245	215-275	0-30	244	2	0,3	12,6	18	12		16
DN250	185	245	215-275	0-30	299	2	0,4	14	21	11		16
DN300	180	250	210-280	0-35	353	2	0,4	16	24	9		16
DN350	180	250	210-280	0-35	400	2	0,4	16,5	25	9		16
DN400	220	290	265-335	0-35	450	2	0,4	17	28	11	All dimensions out of thickness	16
DN450	180	250	215-285	0-35	500	2	0,4	18,5	30	8		16
DN500	230	280	280-330	0-25	550	2	0,4	22	30	9		16
DN550	240	290	290-340	0-25	600	2	0,4	22	30	9	Acc. To DIN 86 0 44 / EN1092-1/ ASME B16.5 / ASME B16.47/ JIS	20
DN600	230	280	275-325	0-25	650	2	0,4	24	31	8		20
DN650	230	280	275-325	0-25	700	2	0,4	24	31	8		20
DN700	230	280	275-325	0-25	750	2	0,4	27	34	7		20
DN750	230	290	275-335	0-30	800	2	0,5	27	34	7		20
DN800	230	290	275-335	0-30	850	2	0,5	27	39	7		20
DN850	230	290	275-335	0-30	900	2	0,5	27	39	7		20
DN900	230	290	275-335	0-30	950	2	0,5	32	42	6		20
DN950	230	290	275-335	0-30	1000	2	0,5	32	42	6		20
DN1000	230	290	275-335	0-30	1050	2	0,5	38	45	5		20
DN1050	230	300	275-345	0-35	1100	2	0,6	38	45	5	20	
DN1100	230	300	275-345	0-35	1150	2	0,6	38	52	5	20	
DN1150	230	300	275-345	0-35	1200	2	0,6	38	52	5	20	
DN1200	230	300	275-345	0-35	1250	2	0,6	38	52	5	20	

BALANCE IX

Type Approved Expansion Joints

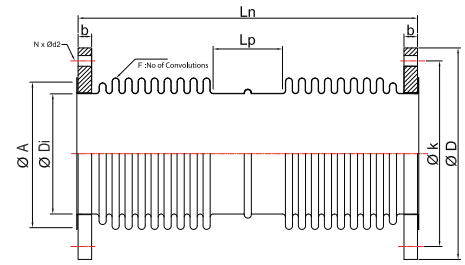

DESIGN VALUES

Bellows Material	304, 304L, 316, 316L, 321
Weld-End Material	Carbon Steel, Stainless Steel
Design Pressure	2,5 barg
Design Temperature	550°C
Drawing No	US3BU-03



**BUREAU
VERITAS**

Nominal Diameter	Length (L _n) (mm)		Movement		Bellows						Flange Dimensions	
	Minimum Length	Maximum Length	Axial (±mm)	Lateral (±mm)	ØA	Pitch	Convolution Height	Number of Convolution (F)	LP	Plies X Thickness	Dimension (mm)	b (mm)
DN80	340	365	38	63	100	8,5	10	2 x 11	115	2 x 0,3		20
DN100	290	315	36	42	141	9,5	13,5	2 x 7	115	2 x 0,3		20
DN125	285	305	32	30	168	11,5	14	2 x 6	105	2 x 0,3		22
DN150	340	370	45	46	196	12	14	2 x 8	105	2 x 0,3		22
DN175	345	375	44	40	224	13	15	2 x 7	120	2 x 0,3		22
DN200	335	365	49	40	244	13	18	2 x 7	120	2 x 0,4		16
DN250	335	365	47	30	299	13,5	22	2 x 7	115	2 x 0,4		16
DN300	310	345	50	26	353	16	24	2 x 6	85	2 x 0,4		16
DN350	310	345	50	24	400	16	25	2 x 6	85	2 x 0,4		16
DN400	375	425	79	35	450	16,5	30	2 x 7	110	2 x 0,5		16
DN450	380	430	71	30	500	19	30	2 x 6	120	2 x 0,5	All dimensions out of thickness	16
DN500	350	390	62	24	550	20	32	2 x 5	120	2 x 0,5		16
DN550	360	400	62	22	600	21	32	2 x 5	110	2 x 0,5	Acc. To DIN 86 0 44 / EN1092-1 / ASME B16.5	20
DN600	440	490	72	31	650	22	33	2 x 6	135	2 x 0,5		20
DN650	440	490	72	31	700	22	33	2 x 6	135	2 x 0,5	20	
DN700	465	520	79	31	750	26	34	2 x 5	165	2 x 0,5	20	
DN750	465	520	79	27	800	26	34	2 x 5	165	2 x 0,5	20	
DN800	465	520	79	27	850	26	39	2 x 5	165	2 x 0,5	20	
DN850	465	520	79	27	900	26	39	2 x 5	165	2 x 0,5	20	
DN900	465	520	79	25	950	32	42	2 x 4	170	2 x 0,5	20	
DN950	465	520	79	21	1000	32	42	2 x 4	170	2 x 0,5	20	
DN1000	465	520	79	21	1050	42	45	2 x 3	175	2 x 0,5	20	
DN1050	465	520	79	19	1100	42	45	2 x 3	175	2 x 0,6	20	
DN1100	465	520	79	19	1150	42	52	2 x 3	175	2 x 0,6	20	
DN1150	465	520	79	17	1200	42	52	2 x 3	175	2 x 0,6	20	
DN1200	465	520	79	17	1250	42	52	2 x 3	175	2 x 0,6	20	

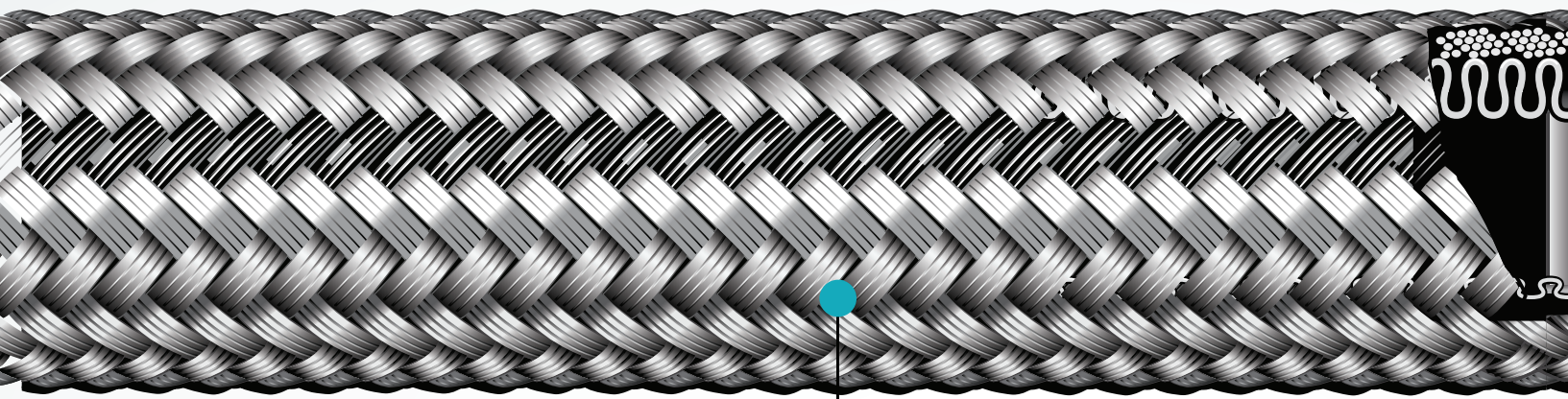

Braid



FLEXIBLE METAL HOSES INSTALLATION INSTRUCTIONS AND USAGE AREAS

Inspection

Establish an inspection schedule based on system application and replacement history.

Electrostatic Discharge

Static electricity can be generated by fluid passing through the hose. Select hose with sufficient conductivity to ground the static electric charge and allow static dissipation. If static electricity generation is possible within an application, choose static dissipative hose and properly ground to earth.

Vibration

Evaluate amount of system vibration when selecting hose. Metal hose may not be appropriate for systems with constant or severe vibration.

Length

Take into consideration hose movement, system pressurization, and thermal expansion when determining hose length. Installing hose that does not have sufficient length to accommodate these factors may reduce hose life.

Minimum Bend Radius

Follow minimum bend radius requirements for your hose. Installing hose with smaller bends may kink hose and reduce hose life.

Hose rupture or leakage may result from bending too close to the hose/fitting connection.

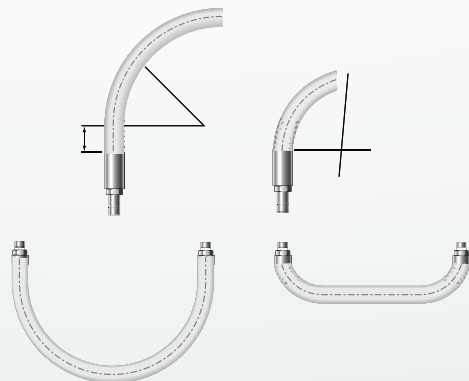

Hose Strain

Elbows and adapters can be used to relieve hose strain.



Motion Absorption

Distribute movement and prevent bends smaller than the hose's minimum bend radius by providing sufficient hose length.

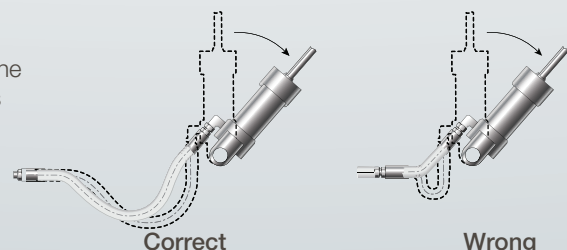

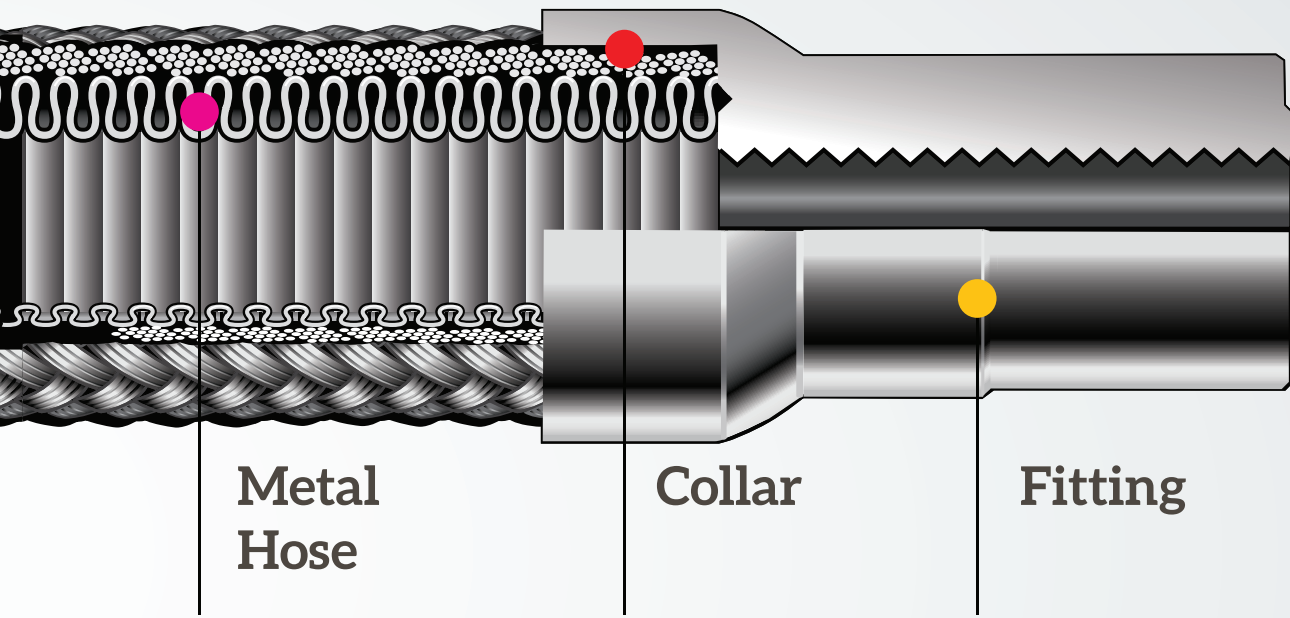

**Metal
Hose**

Collar

Fitting



Machine Tolerance

Allow for changes in length resulting from machine motion and tolerances.



System Pressure Changes

Allow sufficient hose length to accommodate changing system pressures. Do not connect high- and low pressure hoses.

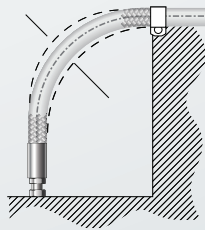

Bending in One Plane

Avoid twisting the hose by bending it in one plane only. For a compound bend, use multiple hose pieces or other isolation methods.

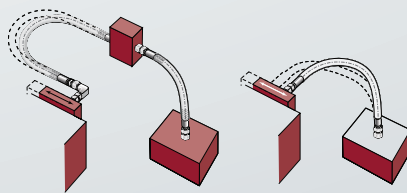

Correct

Wrong

Correct

Wrong

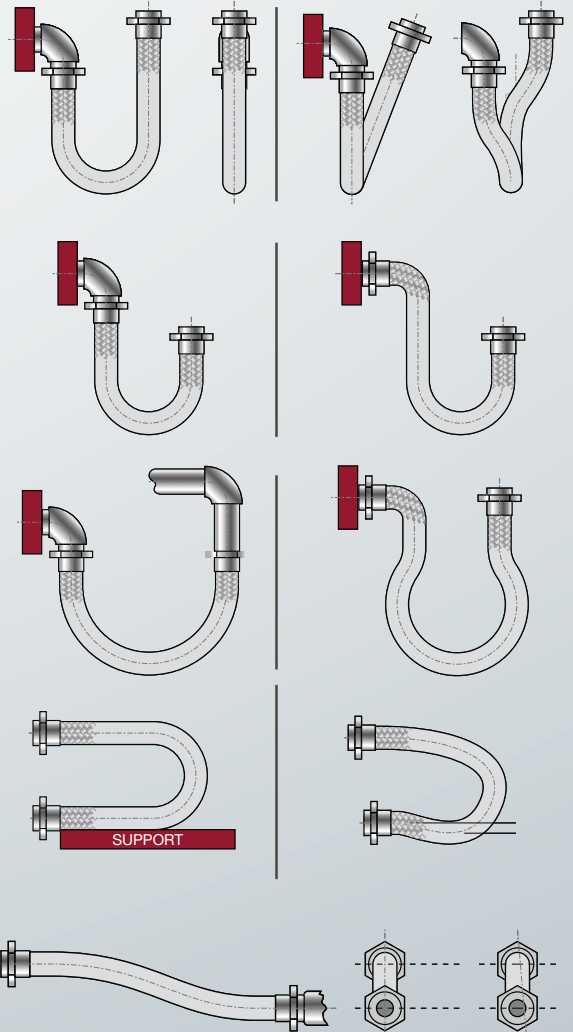

STANDARD

Flexible Metal Hoses

Standard flexible metal hoses are long-lasting since they are manufactured from stainless steel.

Standard flexible metal hoses are manufactured as braided and non-braided.

In line with customer demands hoses can be supplied with various type of fittings.

Standard flexible hoses are manufactured in accordance with EN-10380 standard.

Advantages

- » Long product life
- » Can be used in moving parts
- » Can work at high pressures and temperatures
- » Easy to assemble
- » Hygienic products
- » In line with customer demands, we can manufacture in one piece up to 1.500 meters in desired lengths

Applications

- » Machinery industry
- » Iron and steel industry
- » Pharmaceutical industry
- » Chemical industry
- » Hot & Cold water pipelines
- » Steam pipelines



DESIGN VALUES

Without Braid	MH 201 OG
With Braid	MH 201 MG
Hose Material	304, 316L, 321
Braid Material	304, 316L
Working Pressure	0-245 barg
Sizes	DN6-DN50



201 OG

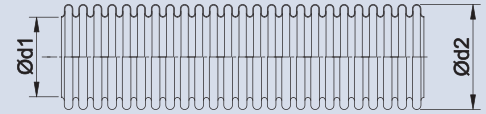

DN		Type	d1	d2	Tolerance	Bending Radius		Working Pressure		Weight (±%10)	Length
						Once-only	Frequent	Permissible Pressure at 20°C (SF3)	Nominal Pressure EN10380 (SF4)		
mm	inch		mm	mm	mm	mm	mm	barg	barg	kg/m	m
6	1/4"	MH 201 OG	6,3	9,6	± 0,2	15	80	24		0,074	10-1000
8	5/16"	MH 201 OG	8,2	12,2	± 0,2	16	125	17		0,087	10-1000
10	3/8"	MH 201 OG	10,3	14,2	± 0,2	18	128	12		0,103	10-1000
12	1/2"	MH 201 OG	12,1	16,7	± 0,2	20	138	9		0,117	10-1000
16	5/8"	MH 201 OG	16,2	21,6	± 0,2	28	160	7		0,177	10-1500
20	3/4"	MH 201 OG	20,3	26,8	± 0,2	32	168	6		0,253	10-1000
25	1"	MH 201 OG	25,3	32,3	± 0,3	40	190	3		0,337	10-600
32	1 1/4"	MH 201 OG	34,3	41,1	± 0,3	50	255	2,5		0,426	10-350
40	1 1/2"	MH 201 OG	40,2	49,8	± 0,3	60	295	2,5		0,706	10-250
50	2"	MH 201 OG	50,3	60,4	± 0,4	70	320	1,6		0,895	10-175

201 MG

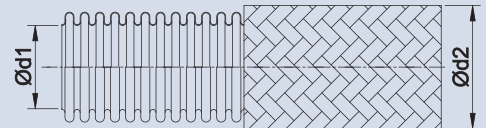

DN		Type	d1	d2	Tolerance	Bending Radius		Working Pressure		Weight (±%10)	Length
						Once-only	Frequent	Permissible Pressure at 20°C (SF3)	Nominal Pressure EN10380 (SF4)		
mm	inch		mm	mm	mm	mm	mm	barg	barg	kg/m	m
6	1/4"	MH 201 MG	6,3	10,8	± 0,2	25	80	245	185	0,160	10-1000
8	5/16"	MH 201 MG	8,2	13,7	± 0,2	32	125	176	132	0,210	10-1000
10	3/8"	MH 201 MG	10,3	15,7	± 0,2	38	128	145	110	0,250	10-1000
12	1/2"	MH 201 MG	12,1	18,1	± 0,2	45	138	93	70	0,275	10-1000
16	5/8"	MH 201 MG	16,2	23,2	± 0,2	58	160	93	70	0,382	10-1500
20	3/4"	MH 201 MG	20,3	28,4	± 0,2	70	168	86	65	0,513	10-1000
25	1"	MH 201 MG	25,3	34,4	± 0,3	85	190	73	55	0,672	10-600
32	1 1/4"	MH 201 MG	34,3	43,2	± 0,3	105	255	60	45	0,915	10-350
40	1 1/2"	MH 201 MG	40,2	52,2	± 0,3	130	295	60	45	1,315	10-250
50	2"	MH 201 MG	50,3	62,7	± 0,4	160	320	40	30	1,610	10-175

LARGE DIAMETER

Flexible Metal Hoses

Large diameter hoses are similar to industrial flexible metal hoses in character and are produced between 2 1/2" - 6".

This type of hoses are used for gas and liquid transfer in large industrial facilities, iron and steel factories, cement factories, fuel oil production and storage facilities, gas distribution facilities.

Large diameter hoses are preferred because of their ease of installation in moving parts.

Our company has become a preferred global brand in large diameter hoses due to the possibility of manufacturing as a single piece in lengths of 100mt or more in line with customer demands.

Advantages

- » Long product life
- » Can be used in moving parts
- » Can work at high pressures and temperatures
- » Easy to assemble
- » Hygienic products
- » In line with customer demands, we can manufacture as a single piece in desired lengths of 100mt or more

Applications

- » Hydraulic systems
- » High pressure pumps
- » Gas distribution lines
- » Machinery industry
- » Chemical industry



DESIGN VALUES

Without Braid	MH 301 OG
With Braid	MH 301 MG
Hose Material	304, 316L
Braid Material	304, 316L
Working Pressure	0-25 barg
Sizes	DN65-DN150



301 OG

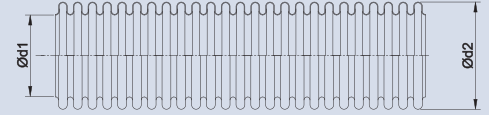

DN		Type	d1	d2	Tolerance	Bending Radius		Working Pressure		Weight (±%10)	Length
						Once-only	Frequent	Permissible Pressure at 20°C (SF3)	Nominal Pressure EN10380 (SF4)		
mm	inch		mm	mm	mm	mm	mm	barg	barg	kg/m	m
65	2 1/2"	MH 301 OG	65,8	77,9	±1,0	110	450	1,2		1,12	5-100
80	3"	MH 301 OG	80,9	95	±1,0	120	520	1		1,5	5-60
100	4"	MH 301 OG	100,2	116,3	±1,0	165	770	1,4		2,25	5-35
125	5"	MH 301 OG	125,8	144,8	±1,2	550	1050	0,8		2,6	1-25
150	6"	MH 301 OG	150,0	170	±1,5	725	1325	0,6		3,2	1-25

301 MG

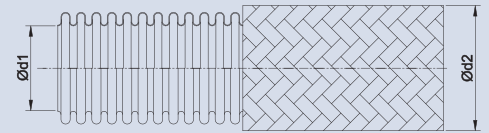

DN		Type	d1	d2	Tolerance	Bending Radius		Working Pressure		Weight (±%10)	Length
						Once-only	Frequent	Permissible Pressure at 20°C (SF3)	Nominal Pressure EN10380 (SF4)		
mm	inch		mm	mm	mm	mm	mm	barg	barg	kg/m	m
65	2 1/2"	MH 301 MG	65,8	81,1	±1,0	205	450	33	25	2,18	5-100
80	3"	MH 301 MG	80,9	98,2	±1,0	235	520	21	16	2,7	5-60
100	4"	MH 301 MG	100,2	119,5	±1,0	295	770	16	12	3,7	5-35
125	5"	MH 301 MG	125,8	148	±1,2	650	1050	16	12	4,4	1-25
150	6"	MH 301 MG	150,0	173,5	±1,5	860	1325	8	6	6,2	1-25

HIGH PRESSURE

Flexible Metal Hoses

It is our product group that meets the needs of our customers at very high pressures with special braiding designs and due to their larger wall thickness compared to industrial type hoses.

In addition to our standard production from DN6 to DN16, production up to DN50 is made in line with customer demands.

Advantages

- » Can withstand high pressures without braid
- » Used in moving parts

Applications

- » Hydraulic systems
- » High pressure pumps
- » Gas distribution lines
- » Machinery industry
- » Chemical industry



DESIGN VALUES

Without Braid	MH 221 OG
With Braid	MH 221 MG
Hose Material	316L, 321
Braid Material	304, 306
Working Pressure	0-345 barg
Sizes	DN6-DN150

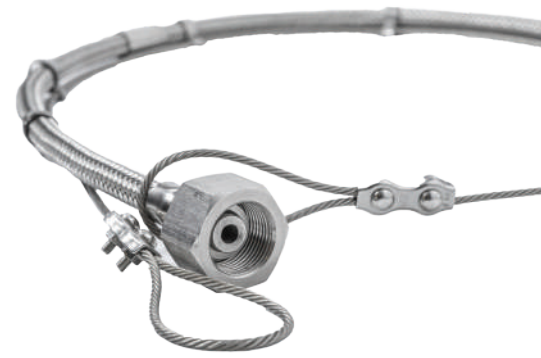

221 OG

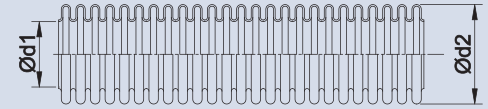

DN		Type	d1	d2	Tolerance	Bending Radius		Working Pressure		Weight ($\pm 10\%$)	Length
						Once-only	Frequent	Permissible Pressure at 20°C (SF3)	Nominal Pressure EN10380 (SF4)		
mm	inch		mm	mm	mm	mm	mm	barg	barg	kg/m	m
6	1/4"	MH 221 OG	6,1	10,2	$\pm 0,3$	15	140	43		0,152	10-100
8	5/16"	MH 221 OG	8,1	12,9	$\pm 0,3$	20	180	50		0,213	10-100
10	3/8"	MH 221 OG	10,1	16,1	$\pm 0,3$	25	220	33		0,225	10-100
12	1/2"	MH 221 OG	12,1	18,8	$\pm 0,3$	30	250	32		0,375	10-100
16	5/8"	MH 221 OG	16,2	24,5	$\pm 0,3$	40	300	22		0,585	10-100

221 MG

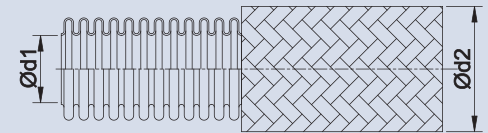

DN		Type	d1	d2	Tolerance	Bending Radius		Working Pressure		Weight ($\pm 10\%$)	Length
						Once-only	Frequent	Permissible Pressure at 20°C (SF3)	Nominal Pressure EN10380 (SF4)		
mm	inch		mm	mm	mm	mm	mm	barg	barg	kg/m	m
6	1/4"	MH 221 MG	6,1	11,6	$\pm 0,3$	25	140	345	255	0,257	10-100
8	5/16"	MH 221 MG	8,1	14,5	$\pm 0,3$	32	180	265	200	0,365	10-100
10	3/8"	MH 221 MG	10,1	17,6	$\pm 0,3$	38	220	220	165	0,470	10-100
12	1/2"	MH 221 MG	12,1	20,4	$\pm 0,3$	45	250	186	140	0,595	10-100
16	5/8"	MH 221 MG	16,2	26,5	$\pm 0,3$	58	300	186	140	0,945	10-100

ULTRA FLEXIBLE

Flexible Metal Hoses

Ultra flexible metal hoses are made of stainless steel, so they are long-lasting.

Ultra flexible hoses are products with closer pitch than standard type hoses making them ultra flexible.

Ultra flexible metal hoses are manufactured as braided and non-braided as standard.

In line with customer demands, they can be supplied with fittings on ends.

Ultra flexible hoses are manufactured in accordance with EN-10380 ultra flexible metal hoses.

Advantages

- » Long product life
- » Can be used in moving parts
- » Can work at high pressures and temperatures
- » Easy to assemble
- » Hygienic products

Applications

- » Machinery industry
- » Iron and steel industry
- » Pharmaceutical industry
- » Chemical industry
- » Hot & Cold water pipelines
- » Steam pipelines



DESIGN VALUES

Without Braid	MH 231 OG
With Braid	MH 231 MG
Hose Material	304, 316L, 321
Braid Material	304, 316L
Working Pressure	0-145 barg
Sizes	DN6-DN80



231 OG

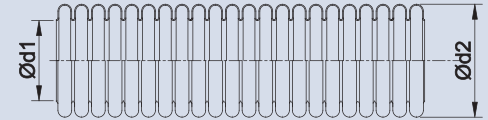

DN		Type	d1	d2	tolerance	Bending Radius		Working Pressure		Weight	Length
						Once-only	Frequent	Permissible Pressure at 20°C (SF3)	Nominal Pressure EN10380 (SF4)		
mm	inch		mm	mm	mm	mm	mm	barg	barg	kg/m	m
6	1/4"	MH 231 OG	6,4	10,5	± 0,2	13	70	24		0,096	10-1000
8	5/16"	MH 231 OG	8,3	12,1	± 0,2	15	95	17		0,110	10-1000
10	3/8"	MH 231 OG	10,3	14,5	± 0,2	15	95	10		0,145	10-1000
12	1/2"	MH 231 OG	12,1	16,7	± 0,2	20	105	8		0,135	10-1000
16	5/8"	MH 231 OG	16,2	22,0	± 0,2	25	120	6		0,230	10-1500
20	3/4"	MH 231 OG	20,2	27,0	± 0,2	32	130	4		0,390	10-1000
25	1"	MH 231 OG	25,1	32,0	± 0,3	40	150	4		0,490	10-600
32	1 1/4"	MH 231 OG	34,3	41,1	± 0,3	50	200	2,5		0,600	10-350
40	1 1/2"	MH 231 OG	40,0	49,9	± 0,4	60	220	1		0,990	10-250
50	2"	MH 231 OG	50,9	60,5	± 0,4	70	240	1		1,160	10-175
65	2 1/2"	MH 331 OG	66,5	78,2	± 1,0	120	340	1		1,45	5-100
80	3"	MH 331 OG	82,5	96,5	± 1,0	150	400	1		1,95	5-60

231 MG

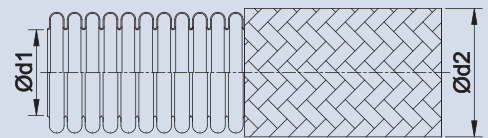

DN		Type	d1	d2	tolerance	Bending Radius		Working Pressure		Weight	Length
						Once-only	Frequent	Permissible Pressure at 20°C (SF3)	Nominal Pressure EN10380 (SF4)		
mm	inch		mm	mm	mm	mm	mm	barg	barg	kg/m	m
6	1/4"	MH 231 MG	6,4	11,7	± 0,2	23	70	145	110	0,190	10-1000
8	5/16"	MH 231 MG	8,3	13,5	± 0,2	30	95	133	100	0,215	10-1000
10	3/8"	MH 231 MG	10,3	16,1	± 0,2	35	95	105	80	0,275	10-1000
12	1/2"	MH 231 MG	12,1	18,4	± 0,2	40	105	105	80	0,260	10-1000
16	5/8"	MH 231 MG	16,2	23,2	± 0,2	45	120	105	80	0,430	10-1500
20	3/4"	MH 231 MG	20,2	28,4	± 0,2	60	130	86	65	0,650	10-1000
25	1"	MH 231 MG	25,1	34,4	± 0,3	80	150	73	55	0,765	10-600
32	1 1/4"	MH 231 MG	34,3	43,2	± 0,3	105	200	60	45	1,070	10-350
40	1 1/2"	MH 231 MG	40,0	51,8	± 0,4	130	220	53	40	1,550	10-250
50	2"	MH 231 MG	50,9	62,7	± 0,4	160	240	40	30	1,810	10-175
65	2 1/2"	MH 331 MG	66,5	80,7	± 1,0	190	340	25	16	2,50	5-100
80	3"	MH 331 MG	82,5	99,0	± 1,0	250	400	13	10	3,00	5-60

SOLAR

Flexible Metal Hoses

Solar-type hoses are products with more open pitch than standard type hoses.

They are lighter than standard hoses. They have a high surface area for excellent heat transfer.

Due to the use of 316L stainless steel, it can be used in drinking water, food production and hygiene needs.

In line with customer demands, 10mt.-20mt.- 25mt.- 50mt.-100mt. such as desired lengths, or It can be shipped with reels up to 1500mt.

Advantages

- » Easy installation with its flexible body and screwed fittings
- » Lightweight and easy to transport
- » Large surface areas
- » Excellent heat transfer properties
- » Can be supplied in one long piece lengths
- » Applicable to heat pump and hybrid systems

Applications

- » Solar energy systems
- » Static usage areas
- » Hot & Cold water pipelines

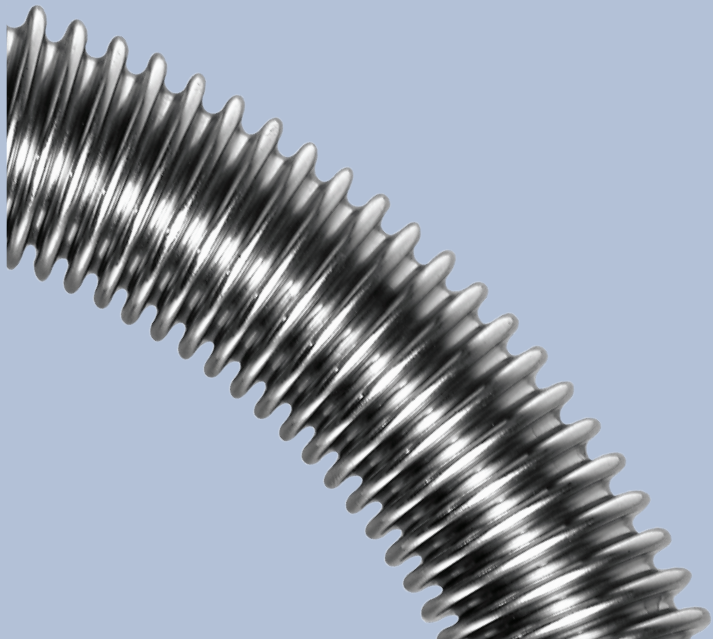

DESIGN VALUES

Without Braid	MH 211 OG
Hose Material	304, 316L, 321
Working Pressure	0-21 barg
Sizes	DN12-DN50



211 OG

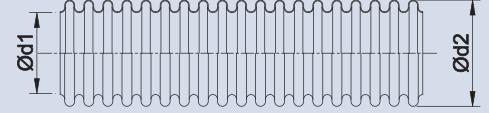

DN		Type	d1	d2	Tolerance	Bending Radius	Working Pressure at 20°C	Surface Area	Weight	Length
mm	inch		mm	mm	mm	mm	barg	m ² /m	kg/m	m
12	1/2"	MH 211 OG	12,4	16,5	± 0,3	20	21	0,072	0,085	10-100
16	5/8"	MH 211 OG	16,3	21,4	± 0,3	25	16	0,096	0,136	10-100
20	3/4"	MH 211 OG	20,4	26,7	± 0,3	30	10	0,136	0,192	10-100
25	1"	MH 211 OG	25,4	31,9	± 0,4	35	10	0,174	0,273	10-100
32	1 1/4"	MH 211 OG	34,5	41,1	± 0,4	40	4	0,203	0,35	10-100
40	1 1/2"	MH 211 OG	40,5	49,6	± 0,4	50	4	0,285	0,56	10-100
50	2"	MH 211 OG	50,7	60,1	± 0,4	60	3	0,35	0,686	10-100

BOILER

Flexible Metal Hoses

Profile of the boiler hoses is similar to solar hoses, but the wall thickness is larger.

These hoses have a longer life at high pressures due to their high wall thickness.

It is used in the manufacture of heat exchangers, especially boilers.

Advantages

- » Large surface areas
- » High heat transfer efficiency
- » Can be supplied in one long piece lengths
- » Heating surface without calcification for heating
- » High acid and corrosion resistance with its stainless steel body
- » Can be installed easily different boiler type with its flexible body

Applications

- » Boiler systems
- » Heat Pumps
- » Hot & Cold water pipelines



DESIGN VALUES

Without Braid	MH 211 K
Hose Material	316L
Fittings Material	304, 316L
Working Pressure	0-10 barg
Sizes	DN20-DN40



211 K

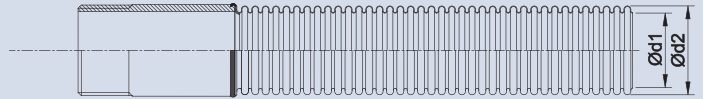

DN		Type	d1	d2	Tolerance	Working Pressure at 20°C	Surface Area	Weight	Length
mm	inch		mm	mm					
20	3/4"	MH 211 K	20,4	26,7	± 0,3	16	0,130	0,305	10-100
25	1"	MH 211 K	25,4	31,9	± 0,4	12	0,191	0,382	10-100
32	1 1/4"	MH 211 K	34,5	41,1	± 0,4	10	0,221	0,553	10-100
40	1 1/2"	MH 211 K	40,5	49,6	± 0,4	10	0,255	0,800	10-100

HT COMPOSITE

Pre-Insulated Hoses

Insulated hoses are used for fluid transfer at high temperatures. Form of these hoses is the same as solar hoses and they contain three layers of insulation.

Fireproof inner layer protects the other layers of the insulation from high temperatures, middle layer prevents heat transfer due to its closed cell structure, and the UV coating on the outer layer protects the product from external effects, sunlight, adverse weather conditions and damage caused by animals such as mice and birds.

Advantages

- » Insulated hoses can be used at high temperature resistant inside layer
- » Weather and UV resistant protective outer layer
- » Easy assembly
- » Middle layer of standard crosslinked PE insulation

Applications

- » It is generally used in the transfer of liquid fluid between solar panels and heat pumps

DESIGN VALUES

Without Braid	MH 211 COMP
Hose Material	316L
Insulation Material	Composite
Working Pressure	0-21 barg
Sizes	DN12-DN25

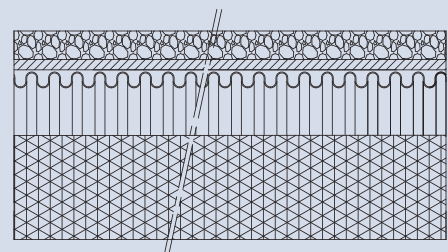
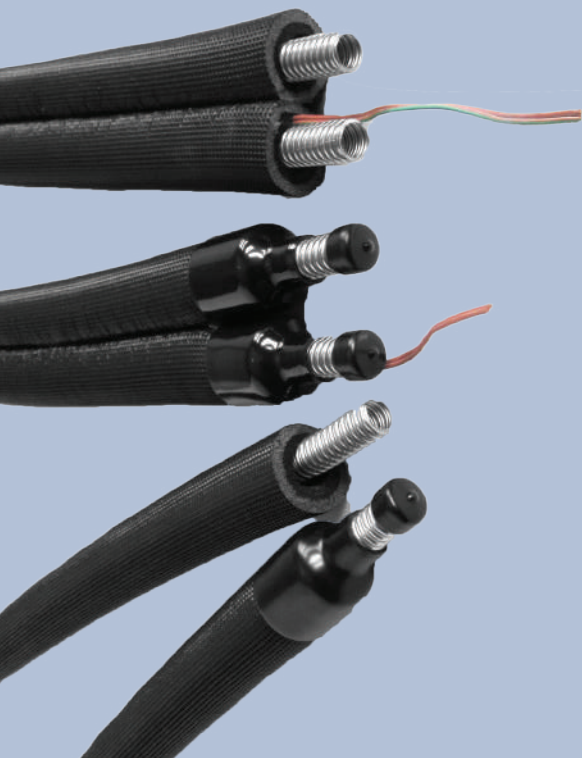

HEAT EXCHANGER

Coils

These product are designed according to customer requests.

Hose shape is similar to solar hose and boiler hose.

This product group is ready-to-install products.

They create cost advantages for manufacturers due to their easy assembly.

Advantages

- » Complete heat exchanger
- » Coil with frame tailor made according to customer specifications
- » Easy assembly

Applications

- » Boiler systems
- » Heat pumps
- » Hot & Cold water pipelines
- » Air fin coolers
- » Air dryer
- » Heat exchanger
- » Cooling systems

DESIGN VALUES

Without Braid	MH 211 K+FR
Hose Material	316L
Fittings Material	304, 316L
Wire Material	304
Working Pressure	0-21 barg
Sizes	DN6-DN50

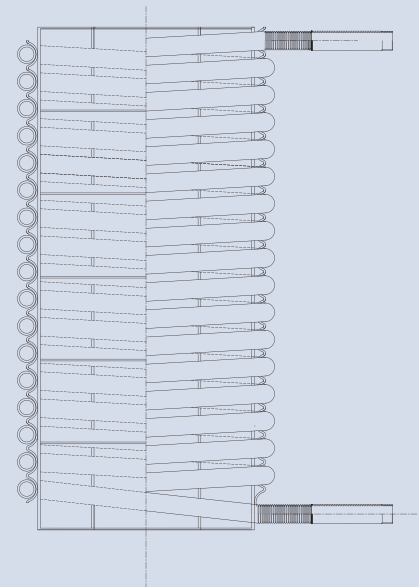

DISTRICT HEATING

Flexible Metal Hoses

These products are specially designed for district heating systems.

Wall thickness is considerably higher than of standard hoses.

They are used in the transfer of high temperature fluids.

Advantages

- » High temperature resistant inside layer
- » Middle layer of standard crosslinked PUR insulation
- » Weather and UV resistant protective outer layer

Applications

- » District heating systems
- » High temperature fluid transfer lines



DESIGN VALUES

Without Braid	DH
Hose Material	304, 316L
Working Pressure	0-21 barg
Sizes	DN30-DN150



DH

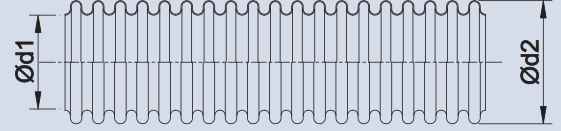

DN	Type	d1	d2	Tolerance	Bending Radius	Wall Thickness	Weight
mm		mm	mm	mm	mm	mm	kg/m
30	DH30	29	34	± 1	200	0,3	0,4
40	DH40	39	44	± 1	200	0,4	0,7
50	DH50	48	55	± 1	250	0,5	1,3
60	DH60	60	66	± 2	300	0,5	1,5
76	DH76	76	85	± 2	400	0,6	2,4
90	DH90	88	98	± 2	450	0,7	3,5
100	DH100	98	109	± 2	600	0,8	4,5
110	DH110	109	119	± 2	650	0,8	4,7
125	DH125	127	139	± 2	800	0,8	5,8
150	DH150	144	156	± 2	950	0,9	7,7

FAN COIL

Flexible Connectors

These products are designed according to customer requests.

Hose shape is similar to solar hose.

This product group is ready-to-install products.

They create cost advantages for manufacturers due to easy assembly.

Advantages

- » Fan-coil connectors are used for flexible connections of fan-coil units to the heating / cooling system distribution piping
- » They are easy to assemble

Applications

- » Fan-coil units
- » Heating / cooling system

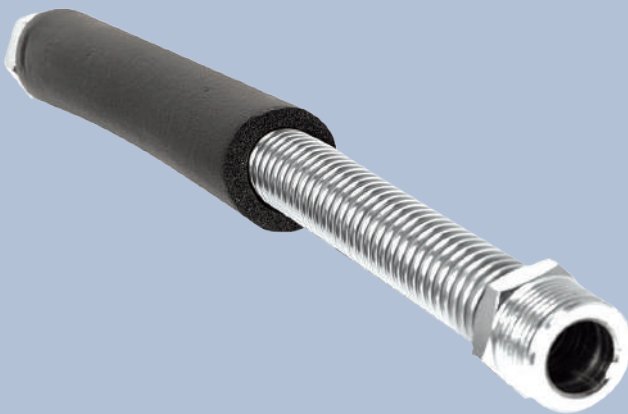

DESIGN VALUES

Without Braid	MH 201 OG, MH 211 OG
With Braid	MH 201 MG
Hose Material	304, 316L
Braid Material	304
Working Pressure	0-21 barg
Sizes	DN12-DN50



201 OG

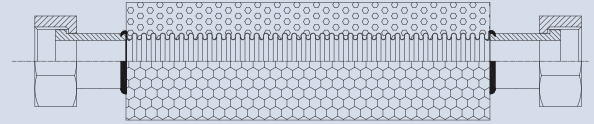

DN		Type	d1	d2	Tolerance	Fitting 1	Fitting 2	Insulation Thickness	Length
mm	inch		mm	mm					
DN12	1/2"	201 OG	12,1	16,7	±0,2	1/2" Male	1/2" Male	13	200-300-400-500-600-700-800-900-1000
DN12	1/2"	201 OG	12,1	16,7	±0,2	1/2" Male	1/2" Female	13	200-300-400-500-600-700-800-900-1000
DN16	5/8"	201 OG	16,2	21,6	±0,2	3/4" Male	3/4" Male	13	200-300-400-500-600-700-800-900-1000
DN16	5/8"	201 OG	16,2	21,6	±0,2	3/4" Male	3/4" Female	13	200-300-400-500-600-700-800-900-1000
DN20	3/4"	201 OG	20,3	26,8	±0,2	1" Male	1" Male	13	200-300-400-500-600-700-800-900-1000
DN20	3/4"	201 OG	20,3	26,8	±0,2	1" Male	1" Female	13	200-300-400-500-600-700-800-900-1000
DN25	1"	201 OG	25,3	32,3	±0,3	1 1/4" Male	1 1/4" Male	13	200-300-400-500-600-700-800-900-1000
DN25	1"	201 OG	25,3	32,3	±0,3	1 1/4" Male	1 1/4" Female	13	200-300-400-500-600-700-800-900-1000

201 MG

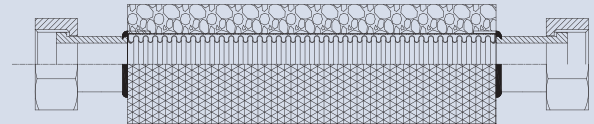

DN		Type	d1	d2	Tolerance	Fitting 1	Fitting 2	Insulation Thickness	Length
mm	inch		mm	mm					
DN12	1/2"	201 MG	12,1	18,1	±0,2	1/2" Male	1/2" Male	13	200-300-400-500-600-700-800-900-1000
DN12	1/2"	201 MG	12,1	16,7	±0,2	1/2" Male	1/2" Female	13	200-300-400-500-600-700-800-900-1000
DN16	5/8"	201 MG	16,2	23,2	±0,2	3/4" Male	3/4" Male	13	200-300-400-500-600-700-800-900-1000
DN16	5/8"	201 MG	16,2	23,2	±0,2	3/4" Male	3/4" Female	13	200-300-400-500-600-700-800-900-1000
DN20	3/4"	201 MG	20,3	28,4	±0,2	1" Male	1" Male	13	200-300-400-500-600-700-800-900-1000
DN20	3/4"	201 MG	20,3	28,4	±0,2	1" Male	1" Female	13	200-300-400-500-600-700-800-900-1000
DN25	1"	201 MG	25,3	34,4	±0,3	1 1/4" Male	1 1/4" Male	13	200-300-400-500-600-700-800-900-1000
DN25	1"	201 MG	25,3	34,4	±0,3	1 1/4" Male	1 1/4" Female	13	200-300-400-500-600-700-800-900-1000

ANNEALED

Flexible Metal Hoses

This type of hose is annealed after forming to eliminate the cold working effects of the forming process. These hoses keep their shape when bent.

The hose profile is similar to solar hose. These hoses are preferred because they are easy to assemble. There is no need to use elbow, reductions or other parts during assembly. No need cutting, threading, welding and so on during assembly.

Annealed flexible metal hoses are manufactured in accordance with EN-15266 standard.

Advantages

- » Easy to assemble
- » Takes desired shape easily
- » Keeps its shape when bent
- » Saves Money and time.
- » It reduces the risk of leakage since it is monolithic.
- » Not required a lot of extra part for assembly.

Applications

- » Gas pipelines
- » Hot & Cold water pipelines



DESIGN VALUES

Without Braid	MH 211
Hose Material	304, 316L, 321
Working Pressure	0-21 barg
Sizes	DN12-DN50



211 AN

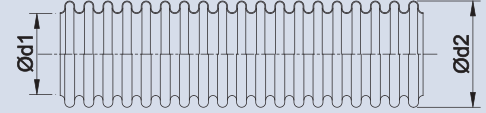

DN		Type	d1	d2	tolerance	Bending Radius	Working Pressure at 20°C	Surface Area	Weight	Length
mm	inch		mm	mm	mm	mm	barg	m ² /m	kg/m	m
12	1/2"	MH 211 AN	12,4	16,5	± 0,3	20	21	0,072	0,085	10-100
16	5/8"	MH 211 AN	16,3	21,4	± 0,3	25	16	0,096	0,136	10-100
20	3/4"	MH 211 AN	20,4	26,7	± 0,3	30	10	0,136	0,192	10-100
25	1"	MH 211 AN	25,4	31,9	± 0,4	35	10	0,174	0,273	10-100
32	1 1/4"	MH 211 AN	34,5	41,1	± 0,4	40	4	0,203	0,35	10-100
40	1 1/2"	MH 211 AN	40,5	49,6	± 0,4	50	4	0,285	0,56	10-100
50	2"	MH 211 AN	50,7	60,1	± 0,4	60	3	0,35	0,686	10-100

COPPER FITTINGS

Flexible Metal Hoses

Hose profile similar to standard hose profile.

They can easily be connected to a copper pipe with silver welding.

This type of hoses is used in water pipelines and plumbing.

Silver welding is used for attaching the hose to copper end connections.

Advantages

- » Quick connection
- » Easy installation
- » Easily replaced
- » Can be restrained
- » Lower over all length with respect to weld end expansion joints

Applications

- » Hot & Cold water pipelines
- » Heat pump system
- » Boiler system
- » Plumbing



DESIGN VALUES

Without Braid	201 OG
PN	0-5
Hose Material	304, 316L, 321
Fittings Material	Copper
Sizes	DN6-DN50



201

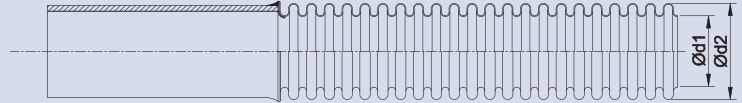

DN		Type	d1	d2	Tolerance	Copper Pipe 1	Copper Pipe 2	Length
mm	inch		mm	mm		mm	barg	
DN6	1/4"	201 OG	6,3	9,6	±0,2	8x1	8x1	400-600-800-1000-1200-1500-2000
DN8	5/16"	201 OG	8,2	12,2	±0,2	8x1	8x1	400-600-800-1000-1200-1500-2000
DN10	3/8"	201 OG	10,3	14,2	±0,2	12x1	12x1	400-600-800-1000-1200-1500-2000
DN12	1/2"	201 OG	12,1	16,7	±0,2	12x1	12x1	400-600-800-1000-1200-1500-2000
DN12	1/2"	201 OG	12,1	16,7	±0,2	12x1	15x1	400-600-800-1000-1200-1500-2000
DN12	1/2"	201 OG	12,1	16,7	±0,2	15x1	15x1	400-600-800-1000-1200-1500-2000
DN16	5/8"	201 OG	16,2	21,6	±0,2	15x1	15x1	400-600-800-1000-1200-1500-2000
DN16	1/2"	201 OG	16,2	21,6	±0,2	22x1	15x1	400-600-800-1000-1200-1500-2000
DN16	1/2"	201 OG	16,2	21,6	±0,2	22x1	22x1	400-600-800-1000-1200-1500-2000

CUT & FIT

Tool Kit

All the tools you need to connect hoses to existing installations or to extend hoses are included in this kit.

This tool is easy to carry due to its light weight.

This tool kit does not need power tools or external power source.

Nipple, nut, ring, gasket and compulsion tool included in this kit.

Advantages

- » Quick connection
- » Easy installation
- » No need for external power source

Applications

- » Hot & Cold water pipelines
- » Solar energy systems
- » Heat pump systems
- » Boiler systems



CONTENTS

Gasket Material	Compressed non-asbestos fibre
Ring Material	304
Nut Material	Brass
Nipple Material	Brass
Reduction Material	Brass

DN		Hose	Segment	Gasket	Nut	Nipple	Reduction	Compression Tool	Compression Tool Collet
mm	inch								
6	1/4"	1/4"	1/4"	1/4"	1/4"	1/4"	-	TYPE 1	DN6-DN6 / DN6-DN8
8	5/16"	5/16"	5/16"	5/16"	5/16"	5/16"	5/16" - 1/4"	TYPE 1	DN8-DN8 / DN8-DN10
10	3/8"	3/8"	3/8"	3/8"	3/8"	3/8"	3/8" - 5/16"	TYPE 1	DN10-DN10 / DN10-DN12
12	1/2"	1/2"	1/2"	1/2"	1/2"	1/2"	1/2" - 3/8"	TYPE 1	DN12-DN12 / DN12-DN16
16	5/8"	5/8"	3/4"	3/4"	3/4"	3/4"	3/4" - 1/2"	TYPE 1	DN16-DN16 / DN16-DN20
20	3/4"	3/4"	1"	1"	1"	1"	1" - 3/4"	TYPE 1	DN20-DN20 / DN20-DN25
25	1"	1"	1 1/4"	1 1/4"	1 1/4"	1 1/4"	1 1/4" - 1"	TYPE 1	DN25-DN25 / DN25-DN32
32	1 1/4"	1 1/4"	1 1/2"	1 1/2"	1 1/2"	1 1/2"	1 1/2" - 1 1/4"	TYPE 2	DN32-DN32 / DN32-DN40
40	1 1/2"	1 1/2"	2"	2"	2"	2"	2" - 1 1/2"	TYPE 2	DN40-DN40

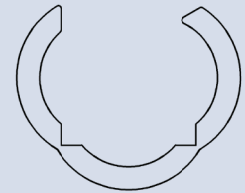
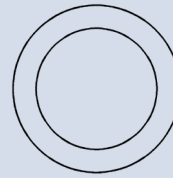
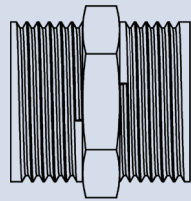
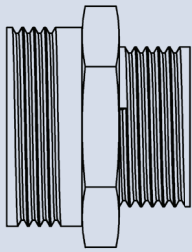

EXPANSION JOINTS PART NUMBER DESCRIPTIONS

Code Example

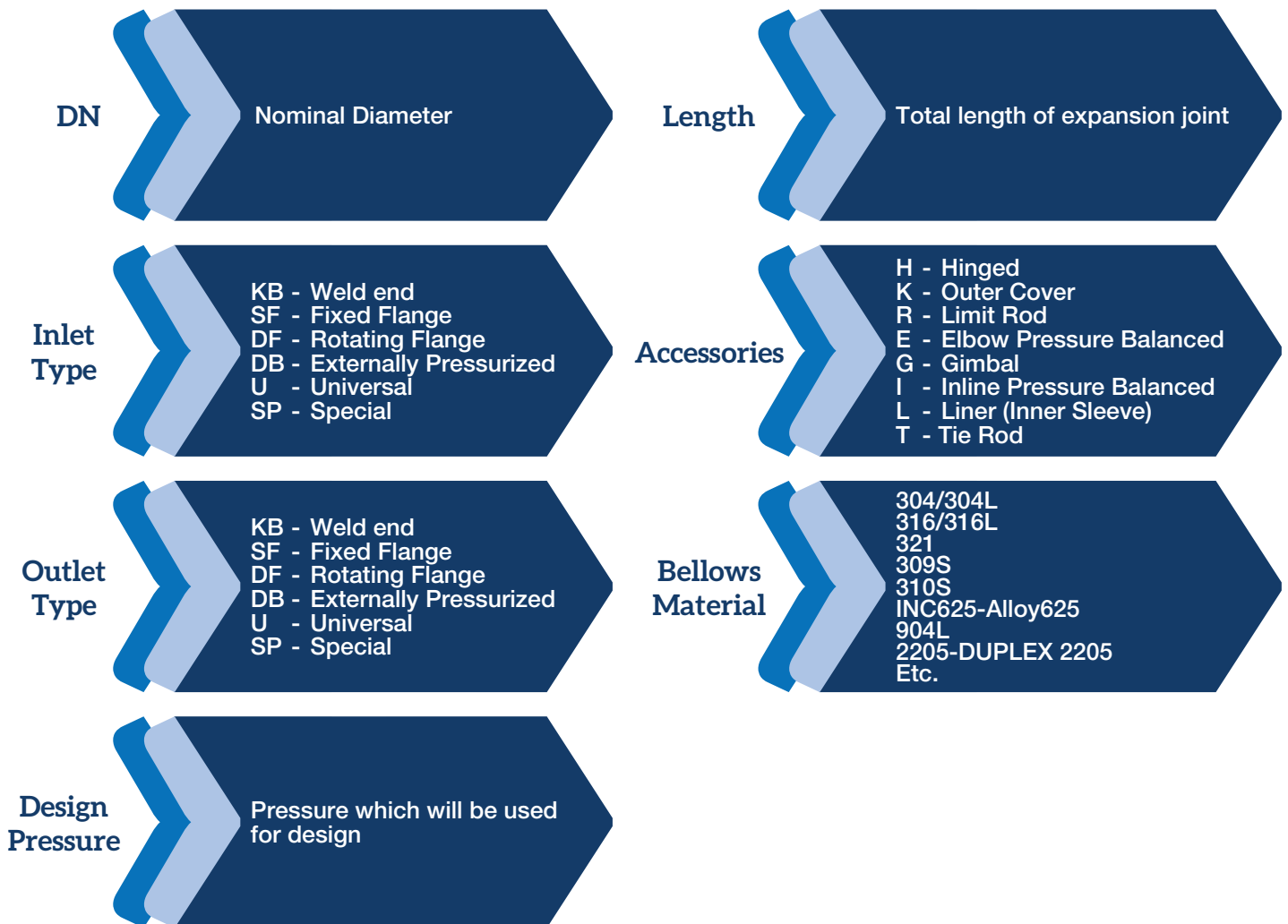
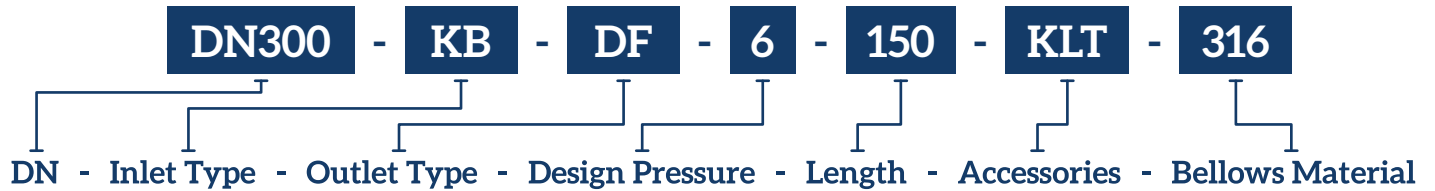

FLEXIBLE METAL HOSES PART NUMBER DESCRIPTIONS

Code Example

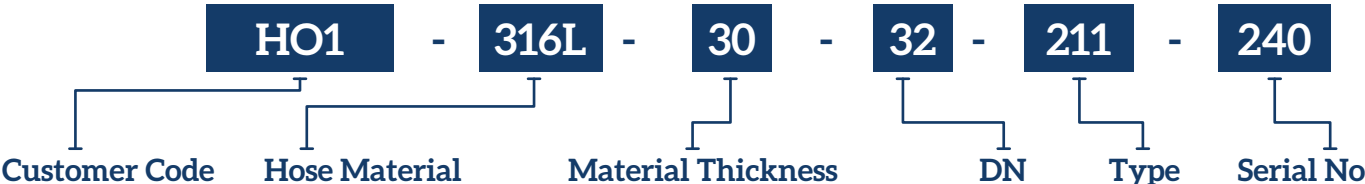

Customer Code	H01 H02 H998 H999	DN	<table border="0"> <tr><td>6</td><td>25</td><td>100</td></tr> <tr><td>8</td><td>32</td><td>125</td></tr> <tr><td>10</td><td>40</td><td>150</td></tr> <tr><td>12</td><td>50</td><td></td></tr> <tr><td>16</td><td>65</td><td></td></tr> <tr><td>20</td><td>80</td><td></td></tr> </table>	6	25	100	8	32	125	10	40	150	12	50		16	65		20	80							
6	25	100																									
8	32	125																									
10	40	150																									
12	50																										
16	65																										
20	80																										
Hose Material	316L 321 304	Serial No	001 002 999																								
Material Thickness	<table border="0"> <tr><td>15-0,15mm.</td><td>40-0,40mm.</td></tr> <tr><td>18-0,18mm.</td><td>50-0,50mm.</td></tr> <tr><td>20-0,20mm.</td><td>60-0,60mm.</td></tr> <tr><td>22-0,22mm.</td><td>70-0,70mm.</td></tr> <tr><td>25-0,25mm.</td><td>80-0,80mm.</td></tr> <tr><td>30-0,30mm.</td><td>90-0,90mm.</td></tr> </table>			15-0,15mm.	40-0,40mm.	18-0,18mm.	50-0,50mm.	20-0,20mm.	60-0,60mm.	22-0,22mm.	70-0,70mm.	25-0,25mm.	80-0,80mm.	30-0,30mm.	90-0,90mm.												
15-0,15mm.	40-0,40mm.																										
18-0,18mm.	50-0,50mm.																										
20-0,20mm.	60-0,60mm.																										
22-0,22mm.	70-0,70mm.																										
25-0,25mm.	80-0,80mm.																										
30-0,30mm.	90-0,90mm.																										
Type	<table border="0"> <tr><td>201 OG</td><td>Standard Hoses Without Braid</td></tr> <tr><td>201 MG</td><td>Standard Hoses With Braid</td></tr> <tr><td>211 OG</td><td>Solar Hoses</td></tr> <tr><td>211 K</td><td>Boiler Hoses</td></tr> <tr><td>221 OG</td><td>High Pressure Hoses With Braid</td></tr> <tr><td>221 MG</td><td>High Pressure Hoses Without Braid</td></tr> <tr><td>231 OG</td><td>Ultra Flexible Hoses Without Braid</td></tr> <tr><td>231 MG</td><td>Ultra Flexible Hoses With Braid</td></tr> <tr><td>301 OG</td><td>Large Diameter Hoses Without Braid</td></tr> <tr><td>301 MG</td><td>Large Diameter Hoses With Braid</td></tr> <tr><td>331 OG</td><td>Ultra Flexible Large Diameter Hoses Without Braid</td></tr> <tr><td>331 MG</td><td>Ultra Flexible Large Diameter Hoses With Braid</td></tr> </table>			201 OG	Standard Hoses Without Braid	201 MG	Standard Hoses With Braid	211 OG	Solar Hoses	211 K	Boiler Hoses	221 OG	High Pressure Hoses With Braid	221 MG	High Pressure Hoses Without Braid	231 OG	Ultra Flexible Hoses Without Braid	231 MG	Ultra Flexible Hoses With Braid	301 OG	Large Diameter Hoses Without Braid	301 MG	Large Diameter Hoses With Braid	331 OG	Ultra Flexible Large Diameter Hoses Without Braid	331 MG	Ultra Flexible Large Diameter Hoses With Braid
201 OG	Standard Hoses Without Braid																										
201 MG	Standard Hoses With Braid																										
211 OG	Solar Hoses																										
211 K	Boiler Hoses																										
221 OG	High Pressure Hoses With Braid																										
221 MG	High Pressure Hoses Without Braid																										
231 OG	Ultra Flexible Hoses Without Braid																										
231 MG	Ultra Flexible Hoses With Braid																										
301 OG	Large Diameter Hoses Without Braid																										
301 MG	Large Diameter Hoses With Braid																										
331 OG	Ultra Flexible Large Diameter Hoses Without Braid																										
331 MG	Ultra Flexible Large Diameter Hoses With Braid																										



KLINGER Turkey Esnek Bağlantı Elemanları
Ticaret ve Sanayi A.Ş
İst. E.T. Serbest Bölgesi 6. Sokak No:111
34957 Tuzla - İstanbul / TURKEY
T: +90 216 540 19 49 » F: +90 216 314 36 16

www.klingerturkey.com